

Operating Data

MARANTZ POWER AMPLIFIER

Model 5

A warranty card, bearing the serial number of the unit you purchased and listing warranty terms, is enclosed with each unit that leaves our plant. For your protection, it is most important that you properly fill in this card and return it promptly after purchase. Should you not find this card enclosed, it is the responsibility of the dealer, from whom you purchased the unit, to supply this card to you.

PRELIMINARY:

For those amplifiers shipped with extra perforated grille, the grille is held in place by two spring clamps. It can be removed most easily with a light pull upward and slightly outward. Do not attempt to pry along top or side with tools or damage to finish may result. Remove all protective packing around tubes and replace grille after carefully positioning flush with sides. A little pressure will snap it back into place.

Input and output cables may be attached and dressed down the front (through slot in front of grille if used) and under the amplifier where they can be led out the back.

OPERATING LINE VOLTAGE:

117 Volts, 60 cycles (for A. C. operation only). All specifications are based on this voltage. The usable range is from 105 to 125 volts, 50-60 cycles.

PLACEMENT OF AMPLIFIER:

For ventilating purposes, it is advisable to locate the amplifier so as to provide some air space on all surfaces.

Because of its distribution of weight, this unit may be placed on a shelf with its forward area extending several inches.

INPUT CONNECTION:

The standard "INPUT" is recommended for most use. At this connection a 1.3 volt signal will drive the amplifier to its full output. A subsonic filter rolls off frequencies below 20 cycles so as to suppress speaker "breathing" and other subsonic disturbances.

The "GRID" input is specially used for production tests. It is without the above-mentioned filter, carrying the low frequency response flat to below 2 cycles. It has the same input sensitivity as the "INPUT" connection. This input is not recommended for most use.

OUTPUT CONNECTIONS:

Use "COM" (Common return) on amplifier output terminal strip together with impedance tap on right which matches speaker impedance.

For maximum efficiency and lowest distortion, it is generally advisable to match the rated speaker impedance with the closest designated output impedance terminals on the amplifier, i.e.:

16 or 15 ohm speaker to Amp. 16 ohm tap
8 ohm speaker to 8 ohm tap
4 or 3 ohm speaker to 4 ohm tap

The correct amplifier output impedance for multiple speakers should be chosen after evaluating the total speaker impedance of all speakers combined (either in parallel or series connection), i.e.:

two 16 ohm speakers in parallel - 8 ohm tap
two 8 ohm speakers in parallel - 4 ohm tap
two 8 ohm speakers in series - 16 ohm tap
two 4 ohm speakers in series - 8 ohm tap

Other speaker impedance totals resulting somewhere between the available amplifier impedances should be connected to the closest impedance value while considering the following:

When in doubt, it is always preferable to wire a speaker of a particular impedance rating to a lower rather than higher amplifier impedance tap. When matched to much lower amplifier taps, some loss in power capability will occur, but this is harmless. If speaker is wired to a higher amplifier tap, distortion can result.

To obtain other damping factors, see instructions under "INSTALLATION OF OTHER DAMPING FACTORS."

METERED TESTS AND ADJUSTMENTS:

Each amplifier is carefully adjusted at the factory for proper operation. Nevertheless, the owner should check the operating conditions after 15 minutes when first placed in service and again after the tubes have "aged", perhaps 12 hours. Recheck every few months.

The test and adjustment section of the amplifier is comprised of the following:

- A. An accurate meter calibrated on the right to indicate the proper 50 milli-ampere BIAS condition on each tube.
- B. Two screwdriver adjustments marked BIAS A and BIAS B, are situated below the meter, and are protected from accidental shifting of calibration by black plastic screw-on caps. These should be removed before warming up for test to avoid burning hands on hot tubes.
- C. A test switch having both test positions marked on either side, with spring return to normal (playing position). The test positions correspond to the meter readings and adjustments listed in A and B above.

TEST PROCEDURE:

Before making these tests be sure to turn the volume control fully down on the signal source connected to the amplifier.

- A. Move the Test Switch lever to the BIAS A test position. The meter pointer will swing to the right, indicating the current drawn by tube EL34/6CA7 designated A. Turn the BIAS A adjustment carefully with a screwdriver until the meter reading is on the BIAS line. (This reading will normally vary slightly during use with the line voltage and with warmup. In installation the BIAS may have to be reset. A current much in excess of mark will tend to decrease tube life.)
- B. Repeat this same test and adjustment for BIAS B, being careful to set exactly to the same point.
- C. It may be necessary to repeat tests A and B because of slight interaction of adjustments.

THE FOLLOWING ADJUSTMENTS AND MODIFICATIONS SHOULD BE DONE BY A PERSON AT LEAST PARTIALLY VERSED IN ELECTRONICS:

A.C. BALANCE ADJUSTMENT

There is an adjustment for the A.C. balance (or drive balance) located within the chassis directly in line with the BIAS A control and accessible by removal of bottom grille.

Experience with our 40 Watt amplifier has shown little need for readjusting this setting unless a driver tube is replaced or vastly different output tubes are installed. This adjustment has been carefully made at the factory prior to shipping.

If it should appear necessary to check the A.C. balance, a variable source of sinusoidal voltage of anywhere from 50 to 1000 cycles is necessary. This should preferably be low in distortion (less than 1%), although attenuated line voltage can be used if it hasn't too much distortion. In addition, use of a dummy load resistor is preferable (a resistor approximately equal to one of the output impedances and capable of temporarily dissipating 30 W).

WARNING: OPERATION OF THIS UNIT WITH THE BOTTOM PLATE REMOVED CAN BE A VERY DANGEROUS SHOCK HAZARD. CARE SHOULD BE TAKEN NOT TO TOUCH ANY OF THE ELECTRICAL CONNECTIONS. SOME ARE AT A POTENTIAL OF NEARLY 500 VOLTS!

1. First warm up the amplifier at least 15 minutes and make the BIAS adjustments, being careful to see that they are very closely in balance with each other. This is done, of course, with no signal input.
2. Connect the input signal source and, if available, the dummy load. If no dummy load is available, short the output terminals from "COM" to "16

ohms" (note that a very small input signal will be needed in this case). Now carefully turn up the input signal while testing with switch in BIAS A position until the indicator reaches the little dot on the meter face to the far right. Quickly throw test switch to BIAS B position and check whether indicator is to same point. If not, a slight rotation of A. C. balance control (screwdriver adjustment located under chassis is described above) one way or the other will bring it closer (but will disturb BIAS A setting in opposite direction). Several trials of setting the level of input signal in combination with tests and adjustments of A. C. balance control should bring both readings closely in balance at the dot.

NOTE: If output has been shorted instead of using dummy load, care must be taken to put signal in only briefly (for only 10 or 15 seconds at a time) because the output tubes are over-dissipating in this position, and prolonged test will reduce the life of these tubes.

TRIODE OPERATION:

This amplifier can be made into a comparably excellent triode amplifier with 18 Watts output capability. It is necessary to unsolder the 100 ohm resistors (R 20 and R 21) from the solder terminals on solder terminal strip mounted on the side of the chassis and connect them to pin 3 of their corresponding output tube base. (This will leave resistors from pin 4 to pin 3 on each output tube base. The screen tap wires - green and green/white - remain dead ended at the terminal strip.)

INSTALLATION OF OTHER DAMPING FACTORS:

Although it is felt that most loudspeakers will deliver the best performance with a very high damping factor, some few speaker manufacturers seem to feel that under certain conditions their speakers will operate better with certain lower damping factors. If the owner has any questions about this, he should consult speaker specifications.

By removal of the two jumper wires from the inside terminals corresponding to "COM" and "4" ohms, and replacing them with the resistors listed below, damping factors of 2, 1, or 1/2 are obtainable at the corresponding output terminal. (Observing the amplifier resting on its top, with the front furthest away: one jumper or resistor listed connects the "COM" terminal to the second terminal from the left on the six terminal strip mounted on front lip of chassis; the other jumper or resistor connects from the "4" ohm terminal to the third terminal from left on same strip.

The resistor connected to "COM" terminal in most cases is made up of a series or parallel combination of IRC BW1/2W or 1W wire-wound resistors carried by many jobbers. If substitution is made, total watt dissipation should be at least equivalent. The resistor connected to the "4" ohm terminal should be 1 watt carbon composition, preferably Ohmite carried by many jobbers. Tolerance on these parts should be 10% or better.

FOR APPROXIMATE DAMPING FACTOR OF:

		2	1	1/2
FOR 16 OHM LOADS	Res. from "COM" terminal	1-0.27Ω 1/2W	2-0.82Ω 1/2W in par. (0.41Ω)	1-0.56Ω 1W or 2-0.27Ω 1/2W in ser. (0.54Ω)
	Res. from "4" ohm terminal	1500Ω 1W 300Ω	620Ω 1W	300Ω 1W 1500Ω
FOR 8 OHM LOADS	Res. from "COM" terminal	2-0.39Ω 1/2W in par. (0.195Ω)	2-0.56Ω 1/2W in par. (0.28)	3-1.2Ω 1/2W in par. (0.40Ω)
	Res. from "4" ohm terminal	1500Ω 1W 300Ω	620Ω 1W	300Ω 1W 1500Ω
FOR 4 OHM LOADS	Res. from "COM" terminal	2-0.27Ω 1/2W in par. (0.135Ω)	3-0.62Ω 1/2W in par. (0.207Ω)	2-0.56Ω 1W in par. (0.28Ω) or 4-0.27Ω 1/2W in series-parallel (0.27Ω)
	Res. from "4" ohm terminal	1500Ω 1W 300Ω	620Ω 1W	300Ω 1W 1500Ω

REPLACEMENT PARTS:

Requests for replacement parts should be accompanied where possible with the part number shown on diagram, together with the serial number of the unit for which replacement is intended.

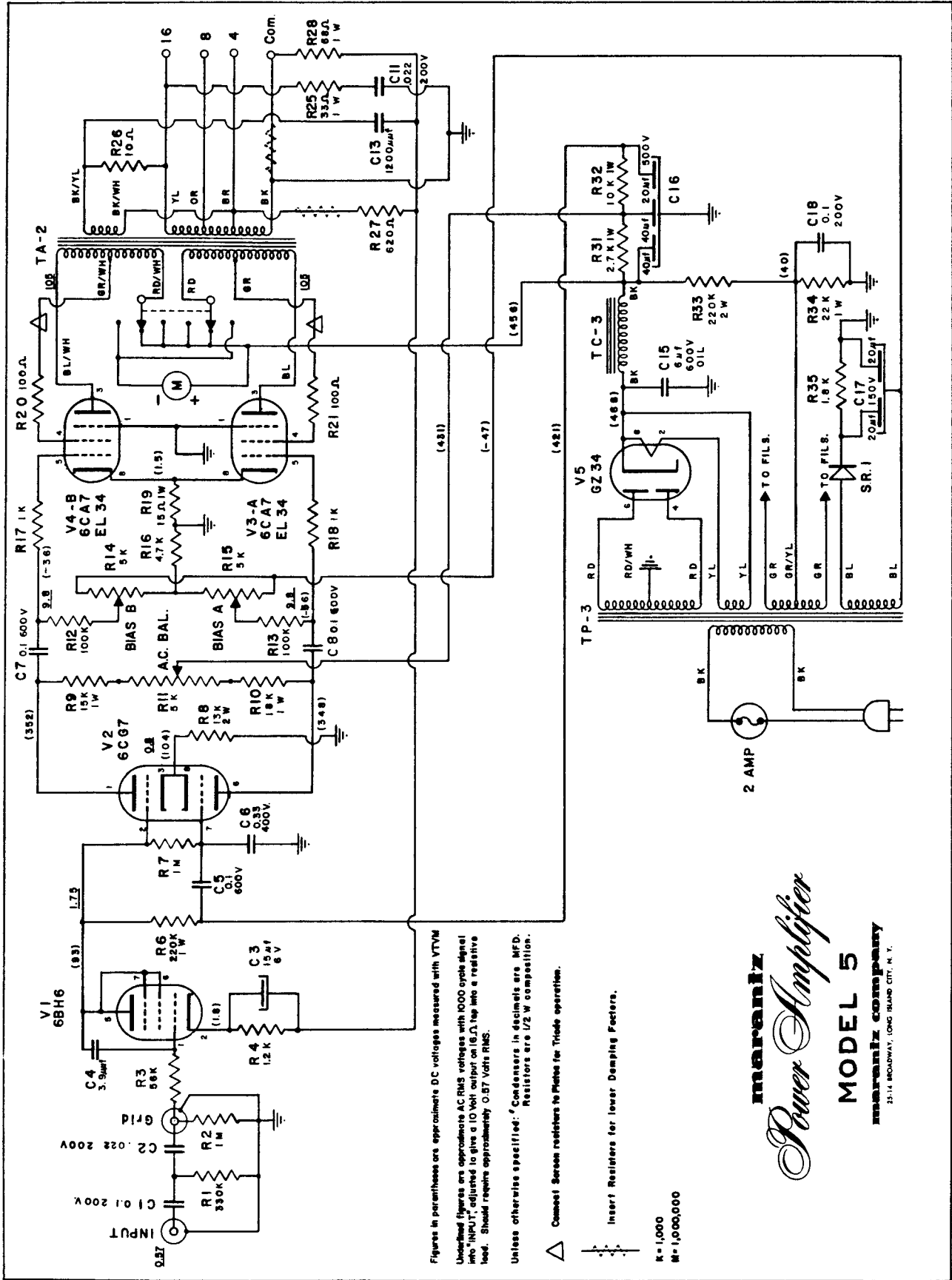

Figures in parentheses are approximate DC voltages measured with VTVM
 Undefined figures are approximate AC RMS voltages with 1000 cycle signal
 into "INPUT", adjusted to give a 10 Volt output on 16.Ω tap into a relative
 load. Should require approximately 0.87 Volts RMS.

Unless otherwise specified: [†] Condensers in decimals are MFD.
 Resistors are 1/2 W composition.

△ Connect Screen resistors to Filtes for Triode operation.

Insert Resistors for lower Damping Factors.

K = 1,000
 M = 1,000,000

marantz
Power Amplifier

MODEL 5
 marantz company
 33-14 BROADWAY, LONG BEACH CITY, N. Y.