

Mopar Model 924 (C-5809) - Chrysler Imperial
made by Philco Corp.

IF = 262.5KC

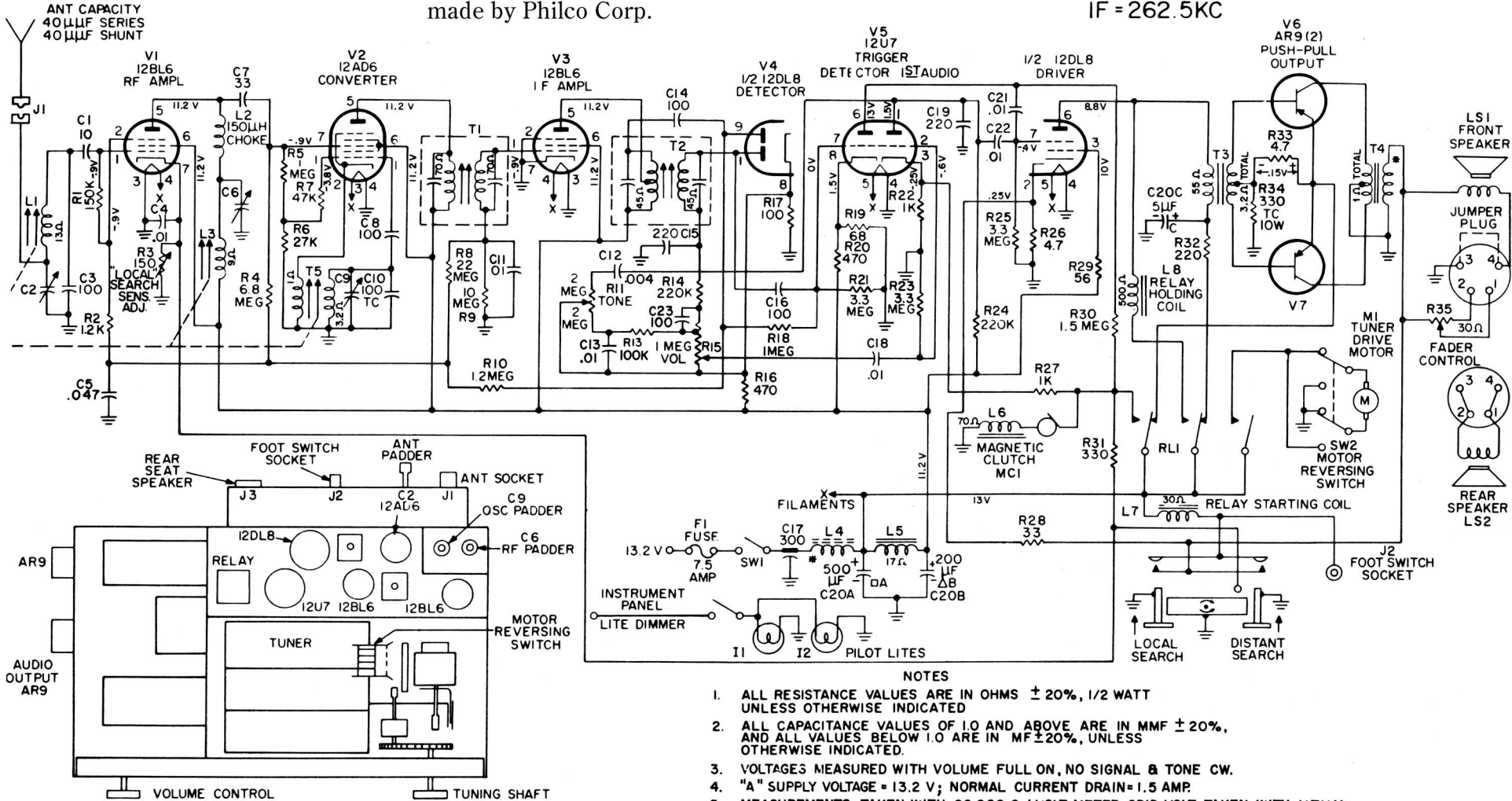

NOTES

1. ALL RESISTANCE VALUES ARE IN OHMS $\pm 20\%$, 1/2 WATT UNLESS OTHERWISE INDICATED
2. ALL CAPACITANCE VALUES OF 1.0 AND ABOVE ARE IN MMF $\pm 20\%$, AND ALL VALUES BELOW 1.0 ARE IN MF $\pm 20\%$, UNLESS OTHERWISE INDICATED.
3. VOLTAGES MEASURED WITH VOLUME FULL ON, NO SIGNAL & TONE CW.
4. "A" SUPPLY VOLTAGE = 13.2 V; NORMAL CURRENT DRAIN = 1.5 AMP
5. MEASUREMENTS TAKEN WITH 20,000 Ω / VOLT METER, GRID VOLT. TAKEN WITH V.T.V.M.

* INDICATES A RESISTANCE OF LESS THAN 1 OHM.