

Assembly
and
Operation
of the



T U B E
T E S T E R
MODEL TT-1A



TABLE OF CONTENTS

Schematic.	2
Introduction.	3
Checking Parts.	3
TT-1 Assembly Changes.. . . .	4
Adapter Assembly.	7
Parts Mounting.	7
Switch Wiring.	8
Tube Socket Wiring.	11
Operation.	19
In Case Of Difficulty.	20
Factory Repair Service.	21
Replacement Parts Price List.	22

The Heath Company reserves the right to discontinue instruments and to change specifications at any time without incurring any obligation to incorporate new features in instruments previously sold.

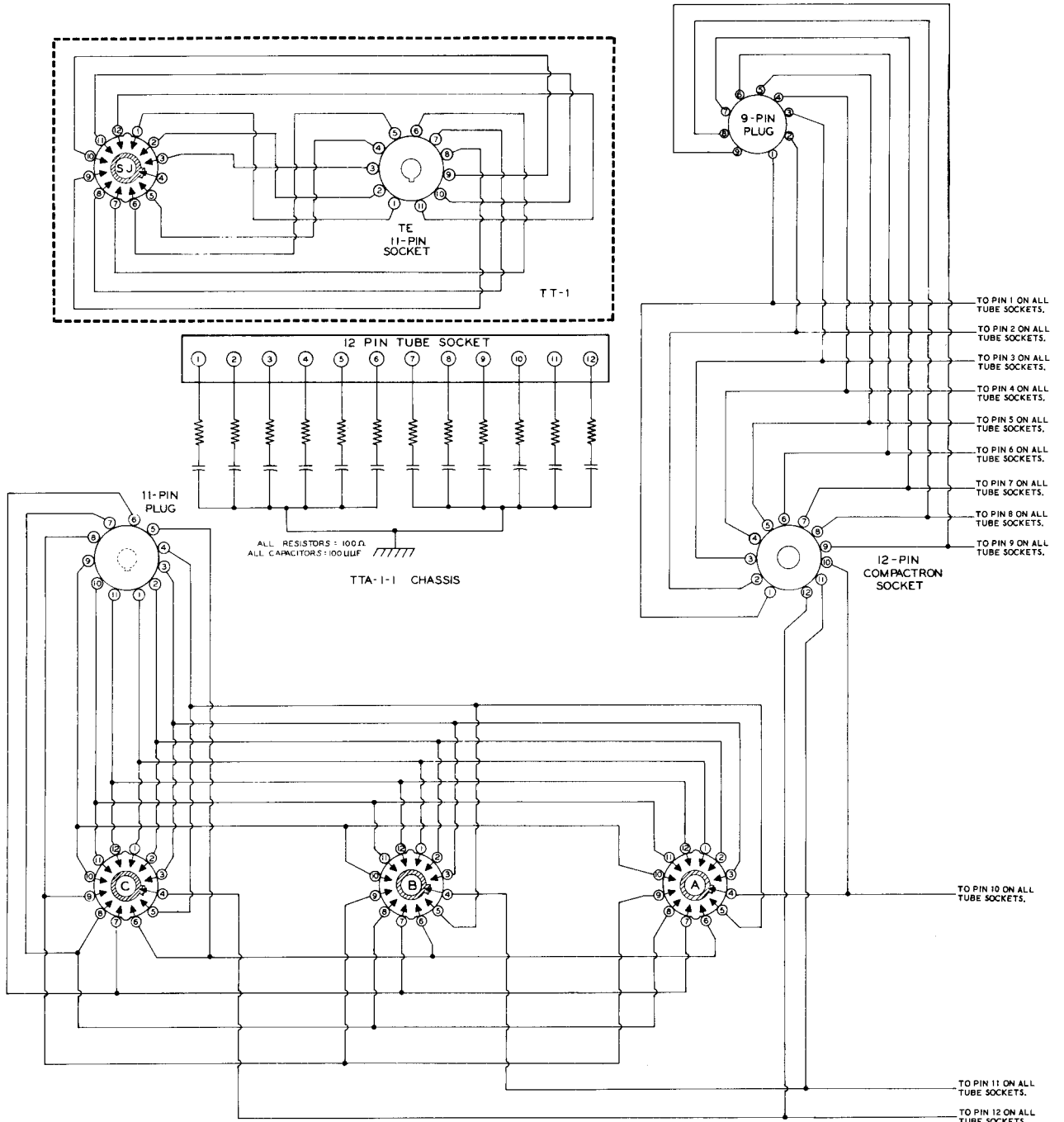

SCHEMATIC OF THE HEATHKIT
TUBE SOCKET ADAPTER
MODEL TT-1A

INTRODUCTION

Your Model TT-1A Tube Tester consists of the TT-1 Tube Tester, plus a Tube Socket Adapter that will enable you to test a greater variety of new tubes than was possible with the TT-1 Tube Tester alone.

To accommodate using the Tube Socket Adapter, it is necessary to make minor changes to the existing circuitry of the Tube Tester. Necessary changes to the Tube Tester can be handled best by working them into the Step-By-Step Assembly instruction of the TT-1 manual before putting the Tube Tester together. To get the manual changes in proper sequence, we suggest that you mark the pages of the TT-1 Manual to indicate that a change is required on the marked page. Then, when a change is needed during assembly of the Tube

Tester, you can refer back to this manual for the new assembly steps and changes.

The parts which make up the Tube Tester and the Tube Socket Adapter are all packed together. However, the Adapter should be wired after the Tube Tester is completed. Therefore, the parts for each unit should be kept separate, according to the Parts Lists in the TT-1 Operational Manual and in this, the TT-1A Manual.

The proper sequence of "What To Do To Get Your TT-1A Tube Tester Together And Operating" is provided in this manual. Use this manual as a guide to coordinate the instructions in the other two manuals, TT-1, furnished with this kit.

CHECKING PARTS

Please mark the following changes in the Parts List of the TT-1 Operation Manual.

Page 18 -

Add:	134-43	1	11-conductor cable assembly
Delete:	434-1	1	Blank socket
Add:	434-118	1	11-pin socket
Delete:	91-50	1	Cabinet
Add:	91-104	X1	Cabinet

After making the preceding changes in the TT-1 Parts List, check the Tube Tester parts. Then check the remaining parts, using the following Parts List. These parts will be used to assemble the Tube Socket Adapter after the Tube Tester is assembled. Set these parts aside until they are called for later.

TUBE SOCKET ADAPTER PARTS LIST

PART No.	PARTS Per Kit	DESCRIPTION
----------	---------------	-------------

Wire-Cable-Sleeving

347-5	1 X	11-conductor cable
347-25	1 X	9-conductor cable
344-50	1	Black hookup wire

PART No.	PARTS Per Kit	DESCRIPTION
----------	---------------	-------------

Wire-Cable-Sleeving (cont'd.)

344-51	1	Brown hookup wire
344-52	1	Red hookup wire
344-53	1	Orange hookup wire
344-54	1	Yellow hookup wire
344-55	1	Green hookup wire
344-56	1	Blue hookup wire
344-57	1	Violet hookup wire
344-58	1	Gray hookup wire
344-59	1	White hookup wire
346-1	1	Length sleeving

Hardware

250-8	3 *	#6 x 3/8" sheet metal screw
250-170	3 *	#6 x 1/4" sheet metal screw
250-49	6	3-48 x 1/4" screw
250-56	4	6-32 x 1/4" screw
252-1	6	3-48 nut
252-3	4	6-32 nut
252-7	3	Control nut
253-10	3	Control flat washer
254-7	6	#3 lockwasher
254-1	3	#6 lockwasher
254-5	3	Control lockwasher
259-1	1	#6 solder lug

<u>PART No.</u>	<u>PARTS Per Kit</u>	<u>DESCRIPTION</u>	<u>PART No.</u>	<u>PARTS Per Kit</u>	<u>DESCRIPTION</u>
<u>Sockets</u>			<u>Miscellaneous</u>		
434-118	1 ✓	11-pin ✓	63-217	3 ✗	Rotary switch
434-119	1 ✗	5-pin Nuvistor ✗	73-1	2 ✓	Rubber grommet
434-139	1 ✗	7-pin Nuvistor ✗	84-18	2 ✗	P.E.C. (Packaged Electronic Circuit)
434-120	1 ✗	9-pin Novar ✗	440-1	1 ✗	11-pin plug cap
434-121	1 ✓	12-pin Compactron ✗	440-4	1 ✗	9-pin plug cap
434-122	1 ✓	10-pin miniature ✗	462-67	3 ✗	Knob
			485-2	2 ✗	Plug button
			203-295-1	1	Panel
			391-34	1 ✗	Blue and white label
				1 ✗	Manual (See front cover for part number,)
					Solder
<u>Plugs</u>					
432-19	1	9-pin ✗			
438-29	1	11-pin ✓			

ROSIN CORE SOLDER HAS BEEN SUPPLIED WITH THIS KIT. THIS TYPE OF SOLDER MUST BE USED FOR ALL SOLDERING IN THIS KIT. ALL GUARANTEES ARE VOIDED AND WE WILL NOT REPAIR OR SERVICE EQUIPMENT IN WHICH ACID CORE SOLDER OR PASTE FLUXES HAVE BEEN USED. IF ADDITIONAL SOLDER IS NEEDED, BE SURE TO PURCHASE ROSIN CORE (60:40 or 50:50 TIN-LEAD CONTENT) RADIO TYPE SOLDER.

TT-1 ASSEMBLY CHANGES

Please make the following changes in the Step-By-Step Assembly instructions of the TT-1 Assembly Manual.

Page 8 - Change the last step in the left-hand column to read:

() 11-pin socket at TE.

Pages 16, 18, 19, and 20 - Change the soldering instructions in all steps that refer to switch SJ to (NS). This includes terminals 1 through 3 and 5 through 12.

Page 28 - After completing all of the steps on Page 28 of the TT-1 Assembly Manual, perform all of the following steps. This additional information concerns installing the 11-pin socket wiring harness so the Tube Socket Adapter can be added later.

Refer to Pictorial 1 (of this manual) for the following steps.

() Position the cable harness (#134-43) as shown. The end with the long gray and white wires should be at switch SJ. Work the harness into place carefully to avoid cutting the harness wire insulation on the sharp chassis edges.

Refer to Detail 1A and connect the socket end of the wiring harness to socket TE as follows:

<u>COLOR</u>	<u>LUG</u>
() Brown	1 (S-1)
() Red	2 (S-1)
() Orange	3 (S-1)
() Yellow	4 (S-1)
() Green	5 (S-1)
() White-black	11 (S-1)
() Black	10 (S-1)
() White	9 (S-1)
() Gray	8 (S-1)
() Violet	7 (S-1)
() Blue	6 (S-1)
() Position the wires of the harness down against the panel,	
() Position the wires of adjacent sockets down against the panel,	

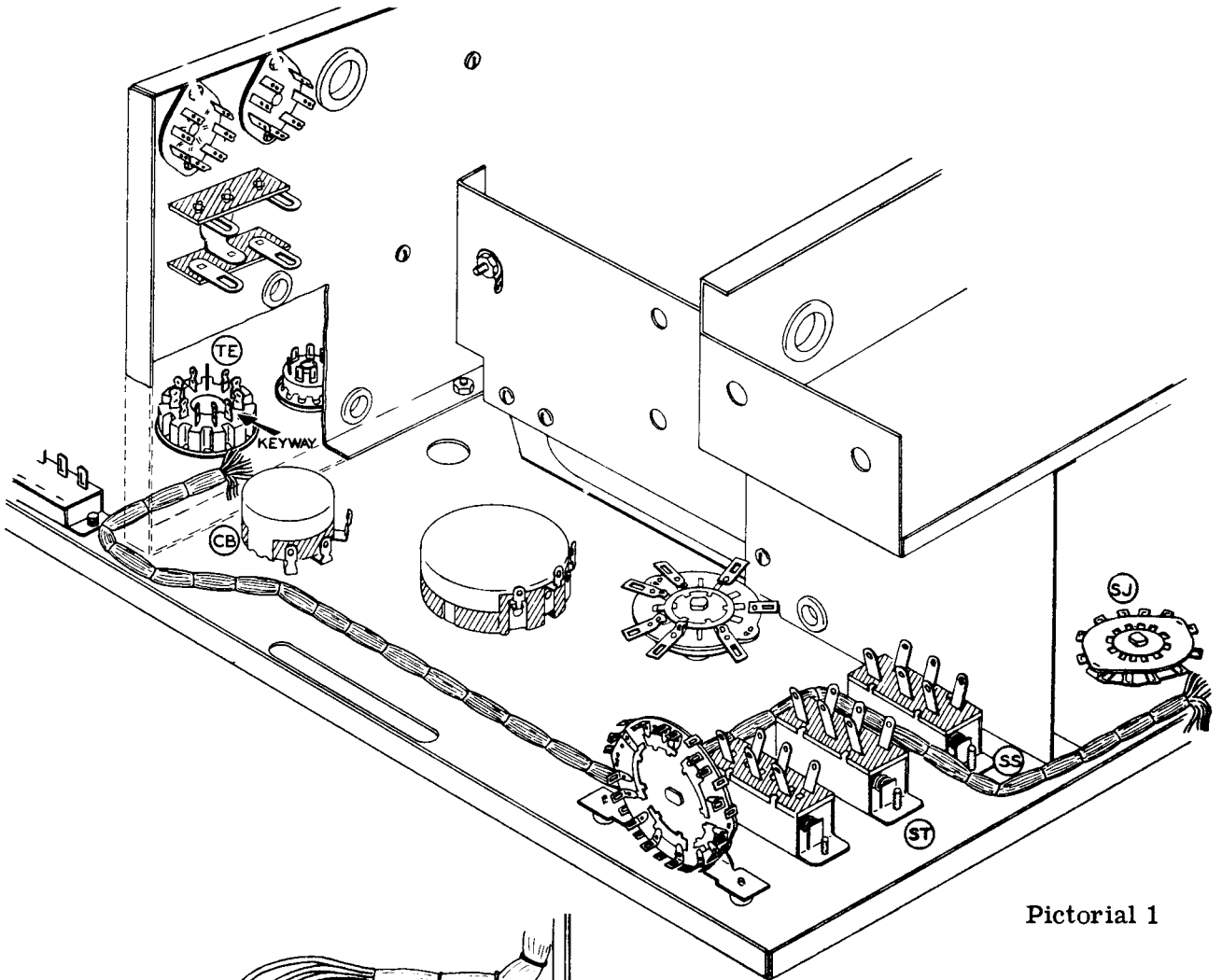

Pictorial 1

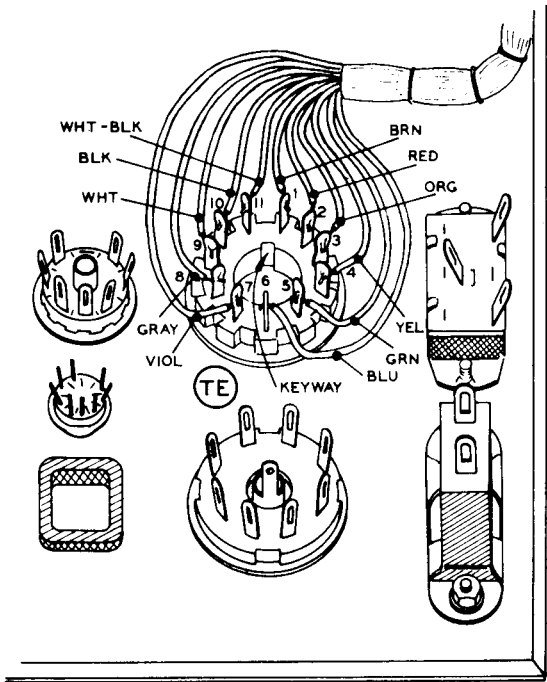

Detail 1A

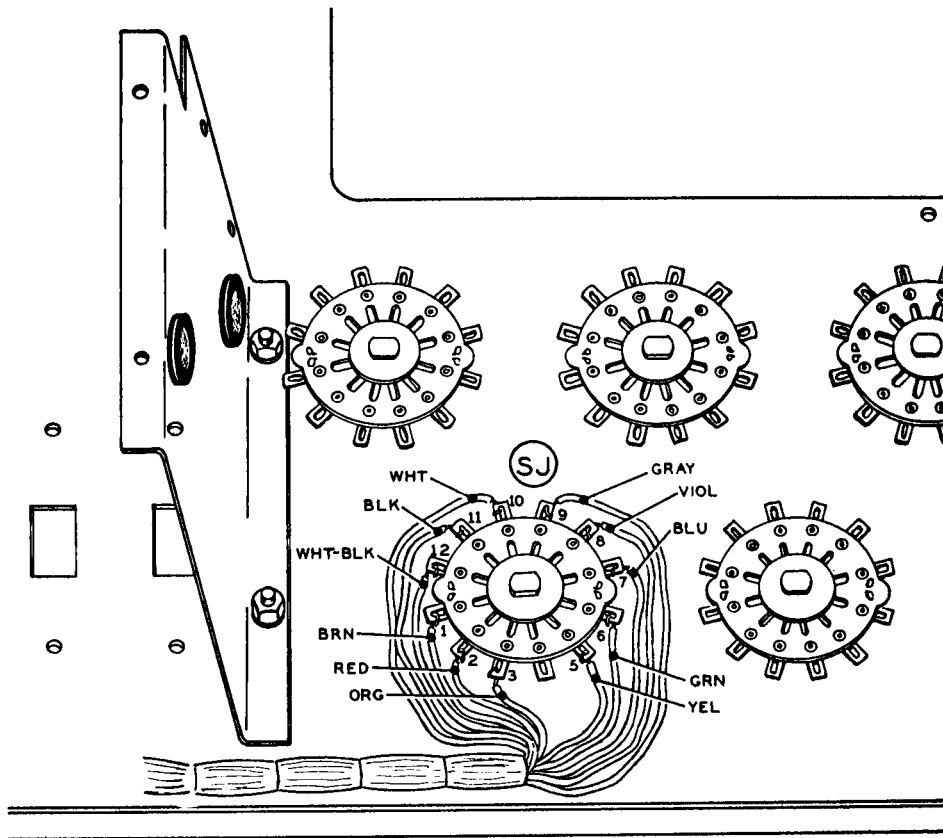

Detail 1B

Refer to Detail 1B and connect the wires at the other end of the harness to switch SJ as follows:

<u>COLOR</u>	<u>LUG</u>
() Brown	1 (S-2)
() Red	2 (S-2)
() Orange	3 (S-2)
() Yellow	5 (S-2)
() Green	6 (S-2)
() Blue	7 (S-2)
() Violet	8 (S-2)
() Gray	9 (S-2)
() White	10 (S-2)
() Black	11 (S-2)
() White-black	12 (S-2)

() Position the wires down against the panel.

() Repeat the continuity test, described under Figure 8 on Page 13 of the TT-1 Assembly Manual, on socket TE. Be sure the switch rotors are in the long (common) clip (#4) during this testing procedure.

() In a like manner, test selector switch SJ by the following instructions 1 and 2 at the bottom of Page 20 of the TT-1 Assembly Manual.

Page 61 - Change the first step in the left-hand column to read:

() Prepare one tube cap with an 18" lead as shown in Figure 77; and prepare the other tube cap with a 24" lead.

Change the second step in the left-hand column to read:

() Pass the 18" tube cap lead through the square panel grommet as shown and connect it to H1 (S-2).

Change the third step in the left-hand column to read:

- () Pass the 24" tube cap lead through the other square panel hole and connect it to J1 (S-2).

This completes changes in the Step-By-Step

Assembly section of the TT-1 Assembly Manual.

After the TT-1 Tube Tester has been completed and tested, refer back to this manual to assemble and install the Tube Socket Adapter, according to the following steps. Use the Adapter Parts that you separated when checking the Parts Lists.

ADAPTER ASSEMBLY

PARTS MOUNTING

Refer to Pictorial 2 for the following steps.

- () Position the Adapter panel as shown.
- (\) Refer to Detail 2A and mount a Selector switch at A on the panel. Use a control lockwasher, a control flat washer, and a control nut. Position the long clip of the switch toward the flange as shown by the large arrows.

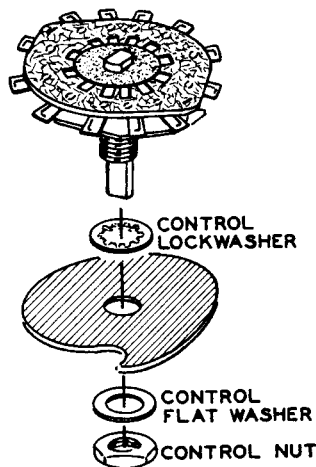

Detail 2A

- (\) In a like manner, mount Selector switches at positions B and C.
- (\) Install the knobs on the switch shafts. Be sure the knob screw is tightened against the flat of the shaft. Rotate the pointer of the knobs to "0" on the panel. Loosen control nut and adjust if necessary for proper knob alignment with the panel markings.

- (\) Refer to Detail 2B and mount the 9-pin Novar tube socket at position F. Use a 6-32 x 1/4" screw, a #6 solder lug, and a 6-32 nut at the rear hole. Use a 6-32 x 1/4" screw, a #6 lockwasher, and a 6-32 nut at the other hole. Position the socket as shown.

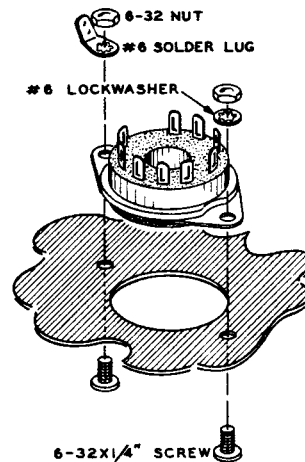

Detail 2B

- (\) Mount the 12-pin Compactron socket at G. Use 6-32 x 1/4" screws, #6 lockwashers, and 6-32 nuts. Position as shown.
- (\) Locate the 10-pin (9-pin with center pin) tube socket and mount it at J. Use 3-48 x 1/4" screws, #3 lockwashers, and 3-48 nuts. Position as shown.
- (\) In a like manner and using the same variety of hardware, mount the 5-pin Nuovistor socket at H, and the 7-pin Nuovistor socket at I. Position as shown.
- (\) Mount 3/8" rubber grommets at K and L.

- () Push a plug button into each of the two blank holes in the panel.
- () Refer to Pictorial 15 and mount the Tube Socket Adapter in the cabinet top. Use #6 x 3/8" screws in the top row of holes, and #6 x 1/4" screws in the bottom row of holes. CAUTION: If the long screws are used on the bottom holes, they will come through the top of the cabinet top.

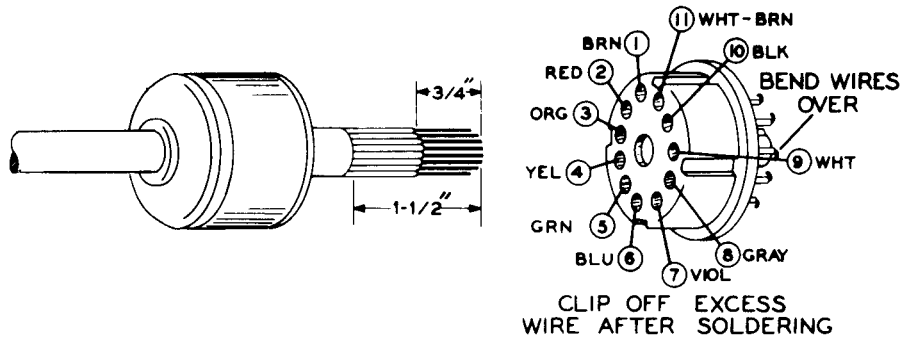

Pictorial 14

NOTE: In the following step, install the identification label where it can easily be seen when needed, but will not show when the unit is in operation. Refer to the numbers on this label in any communications you have with the Heath Company.

- () Carefully peel away the backing paper. Then press the label into position.

This completes the assembly of the Tube Socket Adapter.

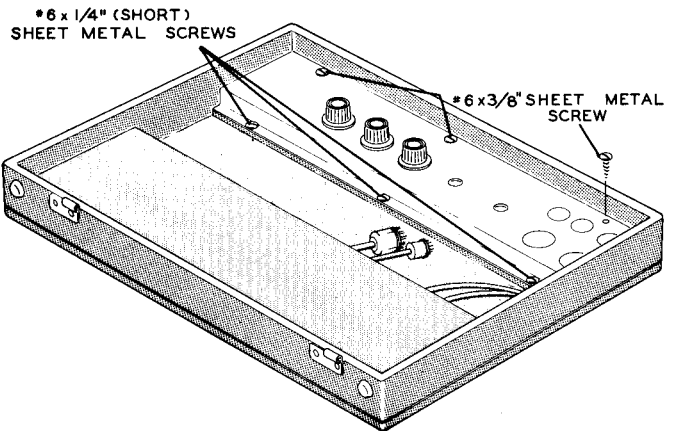

Pictorial 15

OPERATION

When testing a tube in the Tube Socket Adapter, the Tube Tester will function the same as for any of its other tube sockets. Selectors 10, 11 and 12 (on the Adapter) read from left to right, just as in the case of the Tube Tester.

The following procedure should be used when checking a tube in the Tube Socket Adapter.

1. Plug the 9-pin plug extending from the Adapter into the 9-pin socket of the Tube Tester.
2. Plug the 11-pin plug extending from the Adapter into the 11-pin socket of the Tube Tester.
3. Set the controls to the proper settings in accordance with the test data.
4. Place the tube in the proper socket of the Adapter and make the test as with any other

tube. Determine whether the tube is good or bad by following the information given on the roll chart and in the Operation Manual for the Tube Tester.

The majority of tubes that will require testing in the Adapter will be multi-element tubes. Although some tubes having two sections (dual-triode, etc.) can be tested by the use of the K, P, G switches, other tubes may have three sections (triple triode, etc.) and will require more than one setup of the controls. In such a case, always remember to place the Normal-Disconnect switch in the Disconnect position when changing Selectors to prevent damage to the Tester and tube being tested.

There is a handy pocket in the cabinet top for storing the Adapter cables when the Tube Tester is being transported. Room is also available for the Operation Manual and roll chart supplements.