

Review of Demountable vs. Sealed-off Power Tubes*

I. E. MOUROMTSEFF†, ASSOCIATE, I.R.E., H. J. DAILEY†, NONMEMBER, I.R.E., AND
L. C. WERNER†, NONMEMBER, I.R.E.

Summary—The history of demountable and sealed-off types of power tubes is reviewed. Both made their appearance in 1923 as a result of the demand for higher outputs from individual tubes in radio transmitters. The invention of the glass-to-metal seal by Housekeeper made it possible to construct sealed-off water-cooled tubes with copper anodes. Another solution was found by Holweck, in France, who designed a demountable vacuum tube connected to a high-speed rotary molecular pump and continuously exhausted during operation. By designing his molecular pump Holweck could dispense with the mercury-condensation pumps and liquid-air traps which were highly objectionable as a part of standard equipment of a radio transmitter. The main advantage claimed for the demountable tubes by Holweck and other subsequent designers is "unlimited" life. Life of a sealed-off tube is usually determined by the longevity of its filamentary cathode. In a demountable tube a burned-out filament strand can be replaced in a short time. The great majority of radio engineers did not favor the Holweck tubes because of the rotary pump having 4500 revolutions per minute and only 0.001 inch clearance between the rotor and stator. In addition, each time the tube is opened for the filament repair, the actual interruption in tube operation is much longer than the time required to replace the burned-out filament; this is so, because the operating high voltages cannot be applied to the tube until the proper vacuum is re-established. This necessitates having complete duplicate equipment, if uninterrupted operation is of importance. Holweck's tubes were adopted mainly in France.

The advent of the oil-vapor condensation pump invented by Burch, in England, promoted the cause of demountable tubes. Using the new pumps the Metropolitan-Vickers Company immediately built a 500-kilowatt tube for a British Post Office radio station. It was followed by several other types with lower outputs. In this country, the oil-vapor pumps, improved through the work of Hickman and other scientists, served as a basis for designing demountable tubes used in several scientific installations such as super-high voltage X-ray tubes, cyclotrons, etc. In several major European countries, demountable tubes with oil-vapor pumps are now in use in a few radio transmitters and, also, in some industrial installations, mainly, in metallurgical applications.

A review of the sealed-off tubes shows that tubes with 100 up to 350 kilowatts output were designed for radio application during the 1930's both in this country and in Europe by several manufacturing concerns. Their life expectation is up to 10,000 hours instead of the original 2,000 to 3,000 hours with smaller tubes. This makes competition more difficult for the demountable type. It is believed that they have more chance in industrial projects, in which power output required from individual tubes may be greater than conveniently obtained from a sealed-off tube of a practical design, that is, above 400 to 500 kilowatts. Some industrial applications of high-power tubes are reviewed. The application of indirectly-heated cathodes in high-output tubes, similar to the one used in the 350-kilowatt Telefunken tube, is believed probable in the future. Also a semi-demountable design of the medium-sized tubes is suggested

ACCORDING to one definition,¹ a demountable vacuum tube, is a tube "which can be taken to pieces and repaired like an engine" at the place of its use. The history of demountable tubes for radio applications is as old as that of water-cooled tubes of the sealed-off type. Both made their appearance² about 1923, as a result of ever-increasing demands for higher outputs from radio transmitters. Previously, only 50- and 250-watt "glass" tubes were available. Thus, in the historical experiments with transoceanic telephony in 1915 between Arlington, Virginia, and the Eiffel Tower, Paris, several hundred 50-watt tubes were used in parallel. The inconvenience of such an arrangement is too obvious to be discussed. In this country it was soon realized that tubes with much higher individual outputs, say, of several kilowatts, were necessary for long-distance communication and better broadcast service. But such tubes could not be designed after the pattern

* Decimal classification: R331. Original manuscript received by the Institute, January 12, 1944; revised manuscript received, September 6, 1944. Presented, Rochester Fall Meeting, November 8, 1943.

† Westinghouse Electric and Manufacturing Company, Bloomfield, New Jersey.

¹ C. F. Elwell, "The Holweck demountable type valve," *Jour. I.E.E.* (London), vol. 65, pp. 784-785; August, 1927. (Discussion by R. V. Hansford, p. 812.)

² An experimental water-cooled tube with an external copper anode was built by Hauser in Germany in 1918 and another one in Russia by Bonch-Bruevitch. See S. Ganswindt und K. Matties, "Fortschritte in der Entwicklung von Gross-Senderöhren," *Zeit. für Phys.*, vol. 15, pp. 25-30; January, 1934; also, M. A. Bonch-Bruevitch, "High-power tubes with external copper anodes," *Wireless Teleg. and Teleph.* (in Russian), no. 23, pp. 63-67; March, 1924.

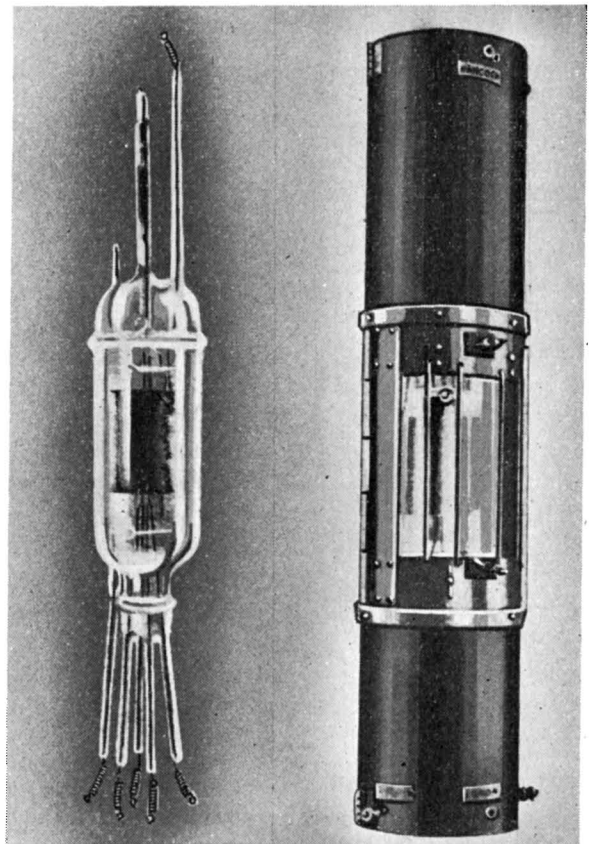

Fig. 1—British silica valve.

of the early 50 and 250 watters. The limitation was in the prohibitively large size of tubes with radiation-cooled anodes mounted within glass envelopes, if power

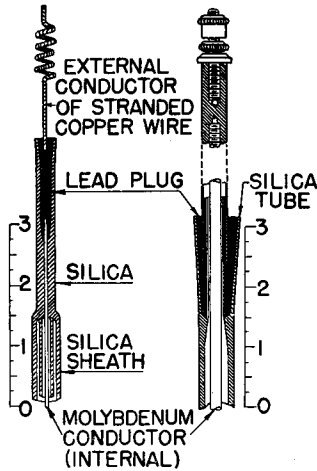

Fig. 2—Silica seals.

output was to exceed 1 or 2 kilowatts per tube. Therefore, the design and construction of tubes with external copper anodes cooled by flowing water or some other

was not discovered³ until 1922. Then, for several years following, the art of actually making glass-to-metal seals was considered a mystery revealed only to highly skilled and highly paid glass blowers; very few of them were available to the vacuum tube industry at that time.

No wonder that other solutions to the problem of making high-output tubes were sought. Thus, the British Navy adopted the design of "silica valves" with power input ratings⁴ up to 20 kilowatts⁵ (Fig. 1). The cylindrical envelopes and hemispherical end portions of these tubes were made of pure quartz and sealed together. The metal parts were assembled inside the en-

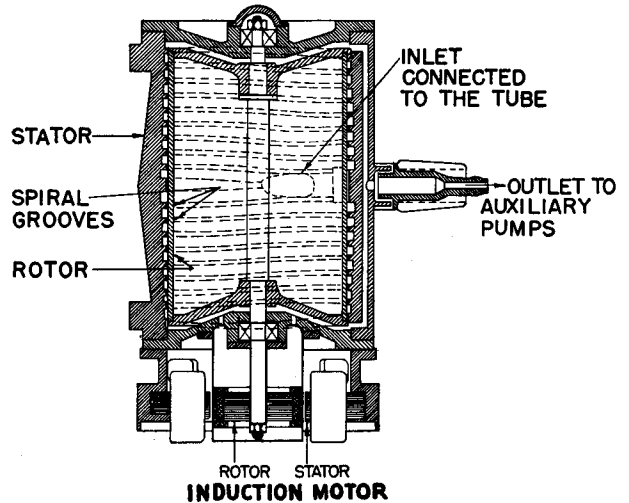

Fig. 4—Holweck's high-speed molecular pump.

velope and supported from the quartz walls. Currents up to 100 amperes could be carried by molybdenum rods sealed through the quartz walls by means of lead plugs formed by molten lead during the tube manufacture (Fig. 2). The silica valves permit higher operating temperature of the anode because the quartz bulbs can stand much higher heat than glass; this type of tube is suitable for low- and medium-power outputs. Their designers asserted that the silica tubes can easily be opened for repair by cutting the end portions on a carborundum disk, reassembled and re-exhausted.

In 1923, Holweck, in France, in order to get around the problem of making glass-to-metal seals, designed a demountable water-cooled tube assembled from several sturdy metal and glass (or quartz) parts with rubber-gasket or ground-glass joints^{1,5} (Fig. 3). During operation the tube is connected to a high-vacuum pump and continuously exhausted for maintaining a proper vacuum. This was a drastic departure from the sealed-off design, which nobody else dared to suggest, because mercury-condensation pumps with liquid-air traps, then in common

³ W. G. Housekeeper, "The Art of sealing base metals through glass," *Trans. A.I.E.E.*, (*Elec. Eng.* June, 1923), vol. 42, pp. 870-876; June, 1923.

⁴ H. Morris-Airey, G. Shering, and H. G. Huges, "Silica valves in wireless telegraphy," *Jour. I.E.E.* (London), vol. 65, pp. 786-790; August, 1927.

⁵ *Compte Rendues de l'Academie de Science*, vol. 177, p. 164; 1923; vol. 178, p. 1803; 1924; vol. 193, July, 1931.

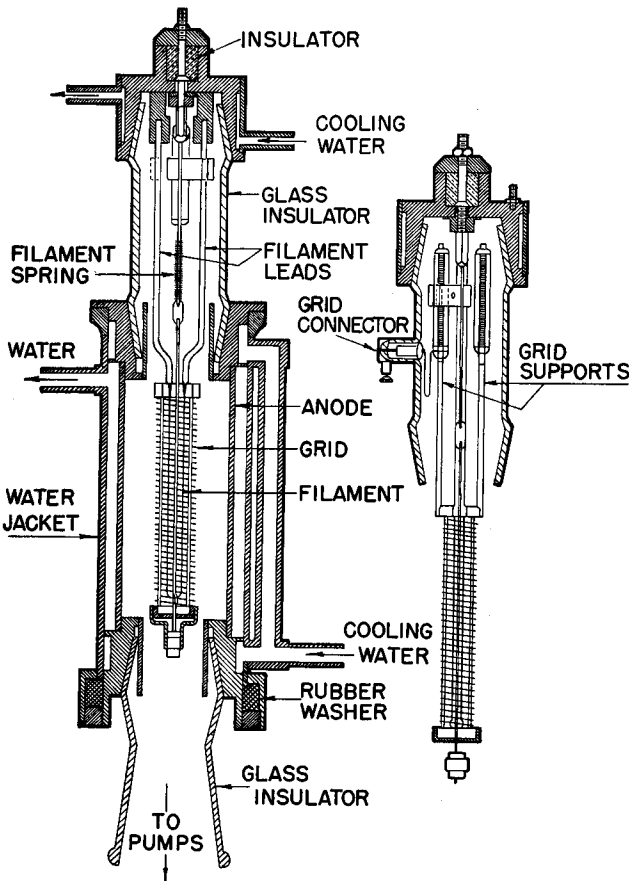

Fig. 3—Holweck's early demountable tube.

fluid was only a natural step for increasing tube output. However, the art of making reliable joints between the copper anodes and the glass bulbs giving support and insulation to the internal tube parts (grid and filament)

use, would not be acceptable as a part of the standard equipment of a transmitting radio station.⁶ Holweck dispensed with the mercury pumps by cleverly designing a high-speed rotary molecular pump which was capable of establishing as good a vacuum as a mercury-diffusion pump without the objectionable liquid air trap necessary (Fig. 4). The Holweck demountable tube was adopted by the French Navy, and in 1927 there were 80 Navy transmitters with 10-kilowatt tubes of this type in operation. In addition, a few land stations employed several 10- and 30-kilowatt Holweck tubes. Later on a 150-kilowatt model was designed by Holweck⁷ (Fig. 5).

No other country favored demountable tubes of the Holweck type, partly, because of the lack of confidence in the commercial value of the rotary pump with 4500 revolutions per minute and less than 0.001 inch clear-

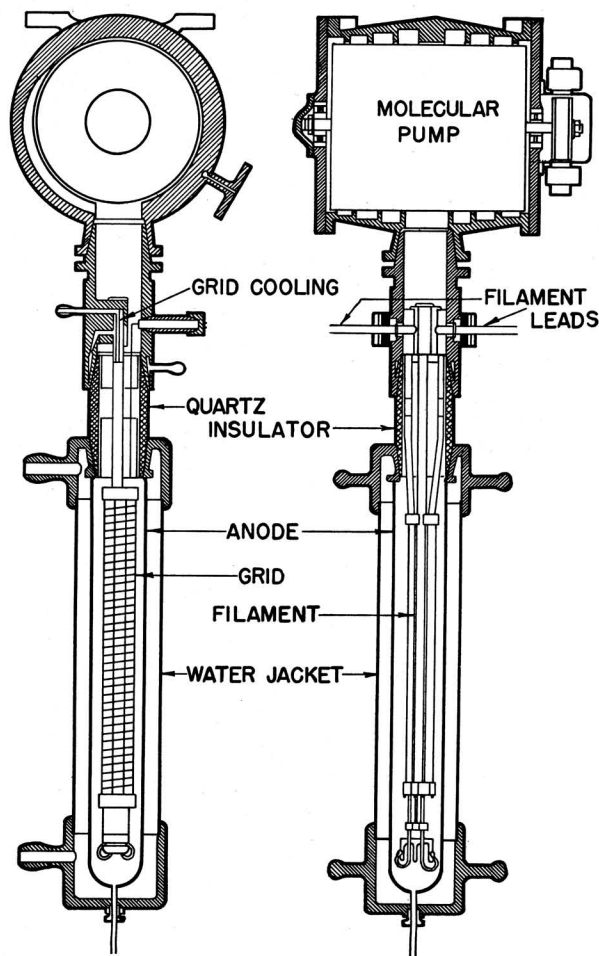

Fig. 5—Holweck's 150-kilowatt demountable tube.

ance between its rotor and stator; but mainly, because at that time all major countries, following the lead of the United States, were in a position to manufacture

⁶ Originally, the idea of the demountable tube was suggested in England during World War I. (See British Patent No. 162367 by Macrorie, Fortescue, Bryan and Morris-Airey.) Experiments were carried out by His Majesty's Admiralty, but were discontinued as unsuccessful.

⁷ F. Holweck and P. Chevalier, "Triode demountable de 150 kilowatt," *Le Genie Civil*, vol. 49, p. 148; June, 1932.

sealed-off tubes of the same size with satisfactory results. Still, the idea of a demountable tube appealed to the minds of radio engineers, and the opinion could



Fig. 6—100- to 200-kilowatt Westinghouse AW-220 tube.

frequently be heard that demountable designs would be in order with tubes of higher outputs than 100 kilowatts. However, with experience rapidly being accumulated, it soon became possible to design and manufacture sealed-off tubes for even higher ratings. The first two large tube types were designed in this country in 1929; these were: the AW-220 of the Westinghouse Company⁸ (Fig. 6) and the UV-862 of the General Electric Company⁹ (Fig. 7). During the 1930's, they were followed by a number of other tubes with outputs from 100 to 350 kilowatts announced here and in Europe by various manufacturers. Some of them are shown in Figs. 8 to 11. The most interesting published data for all these tubes are collected in Table I. There are also tubes of this size made by some other foreign manufacturers not listed in this table. With one exception, all these tubes have a basically similar structure: filamentary cathodes consisting of 6 to 18 parallel tungsten wires 8 to 16 inches long; overwound grids and copper anodes 4 to 5 inches in diameter using

⁸ I. E. Mouromtseff, "A new water-cooled power vacuum tube," *Proc. I.R.E.*, vol. 20, pp. 783-808; May, 1932.

⁹ J. A. Chambers, L. J. Jones, G. W. Fyler, R. H. Williamson, E. A. Leach, and J. A. Hutcheson, "The WLW 500-kilowatt broadcast transmitter," *Proc. I.R.E.*, vol. 22, pp. 1151-1181; October, 1934.

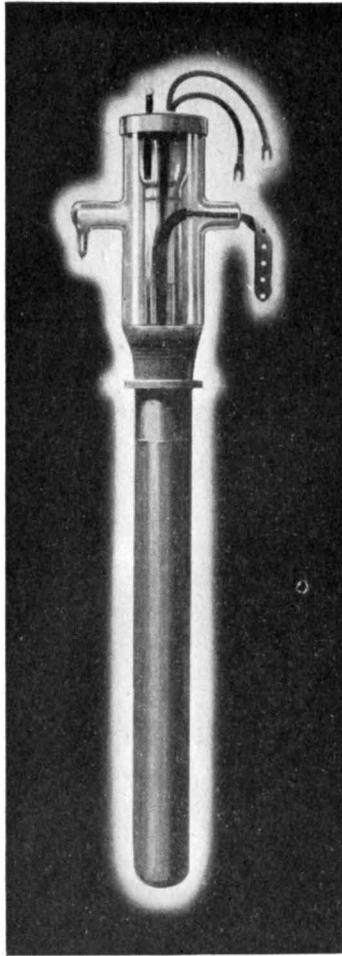

Fig. 7—100-kilowatt General Electric 862 tube.

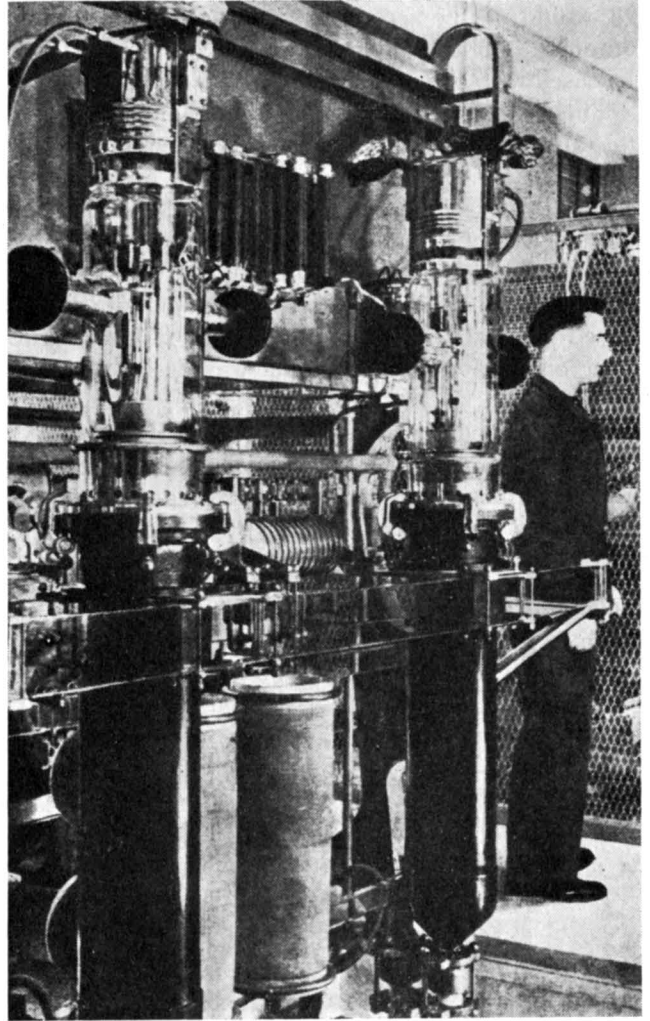

Fig. 9—350-kilowatt tube of Société Française Radio-Électrique.

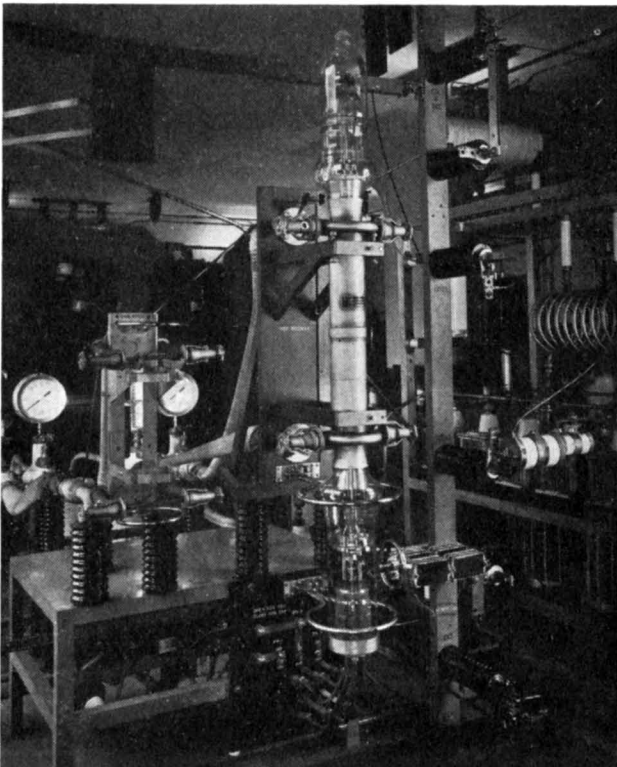

Fig. 8—250-kilowatt Western Electric 320A tube.

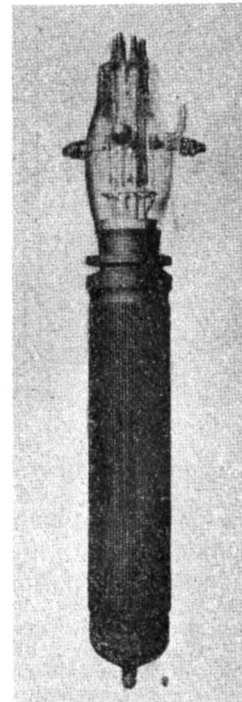

Fig. 10—350- to 400-kilowatt tube of LeMateriel Telephonique (designed by Chevigny).

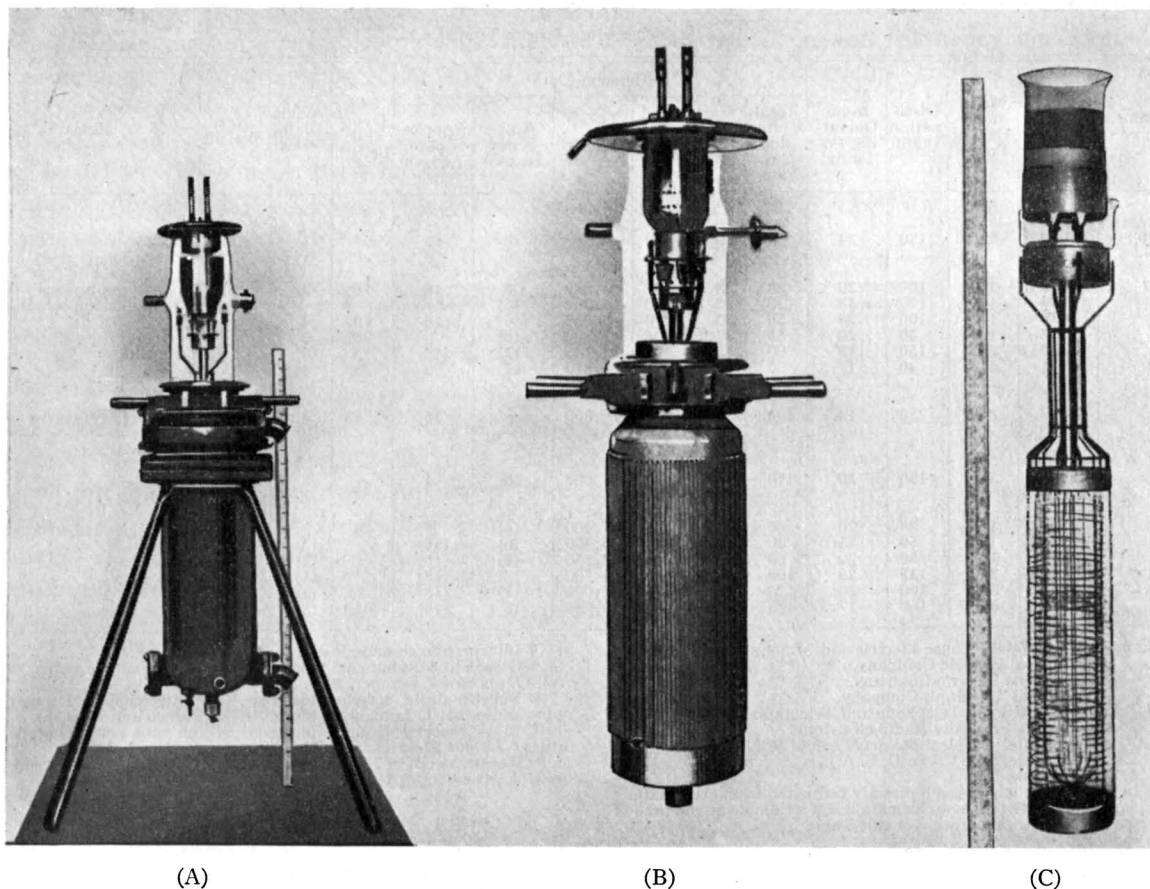

Fig. 11—500-kilowatt (input) Marconi tube.

Housekeeper seals. Filaments and grids are supported from the glass bulb at one end, or on opposite ends of the anode. The filament strands of pure tungsten 0.045 to 0.055 inch in diameter are usually heated by single-phase alternating current, but some tubes are designed for 3- and 6-phase operation. The exception stipulated is the Telefunken tube¹⁰ (Germany) which has an indirectly heated cathode formed by a "Niobium" (= Columbium) cylinder with internal tungsten heaters carrying 1700 amperes at 15 volts. The grid of this tube is made of flat molybdenum rings.

One may notice that all tubes with more than 100 kilowatts output, except for the quite recent Western Electric type 320A, are of foreign make. This is explained by the simple fact that by Federal Radio Commission order No. 115, published more than 10 years ago, the carrier power of the broadcast transmitters in this country is limited to 50 kilowatts. This can easily be taken care of by two tubes in push-pull with 100 kilowatt maximum rating per tube. One may, of course wonder why European countries, being so much smaller than the United States, needed larger tubes than we. The answer is, for disseminating world propaganda under the threat of an approaching World War.

In spite of the evident growth in power output of the sealed-off type of tubes, the idea of building demount-

able tubes has never been abandoned. It was even strongly revitalized in the beginning of the 1930's after a novel oil condensation pump with "apiezon" oil had been developed by Burch of the Metropolitan-Vickers Company to replace the old mercury pumps.¹¹ On the heels of this invention a 500-kilowatt demountable tube was developed by the Metropolitan-Vickers Company utilizing the new pumps.¹² The main advantage of the oil-condensation pump is the elimination of the liquid air or other refrigerants from the exhaust technics. The new huge tube was installed at Rugby radio station (GBR transmitter) of the British Post Office and, after several years experimentation and some improvements, is apparently operated to the satisfaction of the personnel and the owners.¹³ One must note that in our terms this tube would be spoken of as having 350-kilowatt maximum output because the British usually speak of the input, not the output as we do. This first large demountable tube is of a rather complex design. It is actually a combination of 9 tubes within the same anode container (Fig. 12). Its anode is of steel and approximately 24 inches long and 24 inches in diameter. Its internal section is in the form of a polyfoil consisting

¹¹ C. R. Burch, "Some experiments on vacuum distillation," *Proc. Roy. Soc.*, vol. 123, pp. 271-284; March 6, 1929.

¹² "500 kilowatt demountable valves," *Post Office Elec. Eng. Jour.*, pp. 61-64; April, 1932.

¹⁰ S. Ganswindt and K. Matthies, "Fortschritte in der Entwicklung von Gross-Senderöhren," *Zeit. für Tech. Phys.*, vol. 15, pp. 25-30; January, 1934.

¹³ C. R. Burch and C. Sykes, "Continuously evacuated valves and their associated equipment," *Jour. I.E.E. (London)*, vol. 77, pp. 129-146; July, 1935.

TABLE I
 SEALED-OFF HIGH-POWER TUBES

Designers, Name and Tube Type	Approximate Date of Design	Maximum Output Power	Dissipation Limit	Maximum Operating Potential	Filament Data						Tube Overall Length	Anode Diameter	Net Weight	Remarks	Reference
					Total Emission Current	Voltage	Current	Power	Number of Strands	Approximate Length					
		KW	KW	KV	Amps		Amps	Watts		Inches	Inches	Inches	Lbs.		
<i>U. S. A. Designs</i> (W) AW-220	1929	200	150	24	60	30	320	9,600	8	15	63	4	35	Double-ended structure; water-cooled grid; filament springs	8
GE UV-862	1929	100	100	20	40	33	207	6,830	6	16	70	4	30	* 1, 3- or 6-phase filament	9
WE 265A	1934	100	(100)	18	(30)	22	180	4,000	(6)					Double-ended structure	P. D.
GE 898	1936	100	100	20	50	33	210	6,930	6*	16	70	4	30		P. D.
FT 125A	1938	100	40	20	35	27.2	204	5,500	(8)		26	3		† per phase; 3-phase filament	P. D.
WE 320A	1939	250	150	18	90	35	435	15,125	(12)	(15)	75	(4)	56		24
(W) 895	1941	110	40	17.5	50	19	138†	7,870	12	9	25	4.5	25		P. D.
<i>Germany</i> Telefunken	1932	350	250	12	200	15	1700	26,000	‡	16	48	4	190§	‡ Indirectly heated niobium cathode § with jacket	10
<i>England</i> Marconi	1936	350	150	20	110	33	450	15,000	16	1		8			28
<i>France</i> IT and T	1933	120	80	20	40	24	295	5,400	(6)	8	24	3.2	30	Double-ended structure	25
SFR, E-1951	1935	100	50	15	40	30	210	6,300	(6)	(16)		(4)			26
SFR, E-2051	1935	160	80	20	60	35	285	8,550	(8)	(16)		(4)			26
SFR, E-2551	1935	260	135	20	100	35	420	14,700	(12)	(18)		(5)			26
SFR, E-3051	1938	350	160	20	170	35	600	21,000	(18)	(18)		(5)			21
LMT 3067	1939	350	160	17.5	100	30	635	19,050	18	(14)	48	(5)	104		27

Note 1. (W) Stands for the Westinghouse Electric and Manufacturing Company.
 GE General Electric Company.
 WE Western Electric Company.
 FT Federal Telegraph Company.
 IT and T International Telephone and Telegraph Company.
 SFR Société Française Radio-électrique.
 LMT Le matériel Téléphonique (Federal Radio and Telegraph Co. in U. S. A.).
 P. D. Published Data.

Note 2. Figures in parenthesis have been indirectly estimated from other data.

Note 3. Unfilled spaces indicate that no information was available at the time of the preparation of this Table.

²⁴ Information communicated by H. E. Mendenhall.

²⁵ Gibson and Rabuteau, "The new 120 kw thermionic valve," *Elec. Commun.* vol. 12, pp. 86-89; October, 1933.

²⁶ Bulletin de la Société Française Radio-Électrique, "Lampes d'émission," 9-me année, no. 1, January to March, 1935 (French and English).

²⁷ R. Warnecke, "Etude et description d'un tube émetteur scelle de 350 KWS utiles," *L'Onde Électrique*, vol. 17, pp. 49-80; February, 1938.

²⁸ Research staff of Marconi-Osram Co., Ltd., "The development of large transmitting valves," *Marconi Rev.*, pp. 19-21; July-August, 1936.

of 9 petals approximately $2\frac{1}{4}$ inches in diameter on a pitched circle of 9 inches. Each foil has its own grid and filament. The anode is water-cooled. It is insulated by porcelain cylinders, at the bottom from the vacuum tank on which the tube rests and, on the top, from the water-cooled metal flanges supporting the filament and grid structures. The filament and grid structures are shown in Fig. 13. The grid is made of flat horseshoe molybdenum washers clamped to their respective supports and is also water-cooled. In addition to the early large tube, Metropolitan-Vickers later on designed several smaller types (50-kilowatt input) used for the excitation of the 500-kilowatt output stage and, also, in the short-wave GRE transmitter. There are also tubes of a similar design in operation in a 10,000-cycle generator energizing a 20-pound furnace in routine production of special alloys and hard metal.

The oil-condensation pump, particularly with the improvements made in this country by Hickman of the Eastman Kodak Company¹⁴ and some other designers, is gradually taking the place of the old mercury pump in the tube-manufacturing industry. It has also brought forward again the discussion of the possible commercial merits of demountable tubes. In fact, the demountable structures in combination with the oil-condensation pumps immediately found application in the field of superhigh voltage X rays, atom smashing, and other cases of scientific research. One such project, the

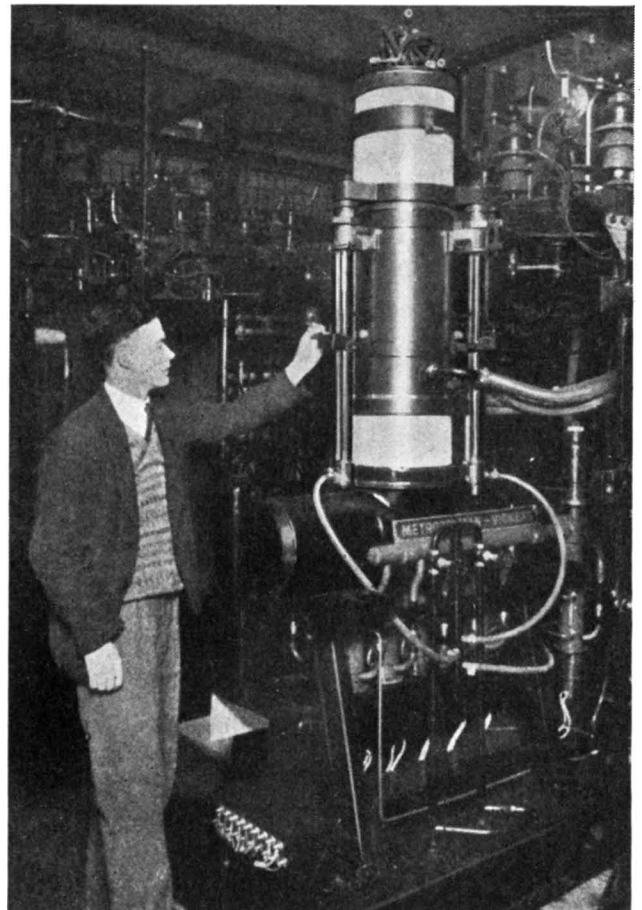

Fig. 12—500-kilowatt (input) Metropolitan-Vickers demountable tube.

¹⁴ K. Hickman, "Vacuum pumps and pump oils," *Jour. Frank Inst.*, vol. 221, pp. 215-236; February, 1936; pp. 383-402; March, 1936.

cyclotron at the University of California, Berkeley, employs two 100-kilowatt demountable tubes for high-frequency energizing of the cyclotron.¹⁵ The tubes and oil-vapor pumps for them were designed by Sloan. The tubes have 4-inch copper anodes and a wound copper grid cooled by water. They have been in operation for several years, and the University personnel working with the cyclotron seem to be quite satisfied with their tube performance.

However, despite this and other favorable comments, the demountable tubes still do not arouse the enthusiasm of the majority of our radio and vacuum-tube engineers, and most of the modern problems of broadcasting and long-distance communication have been, thus far, solved by the use of sealed-off tubes. The reluctance of our electronics engineers to accept the demountable tubes is explained by the lack of assurance that with equal ratings of both kinds of tube the promised advantages of the demountable type will outweigh the expected and, possibly, unexpected disadvantages.

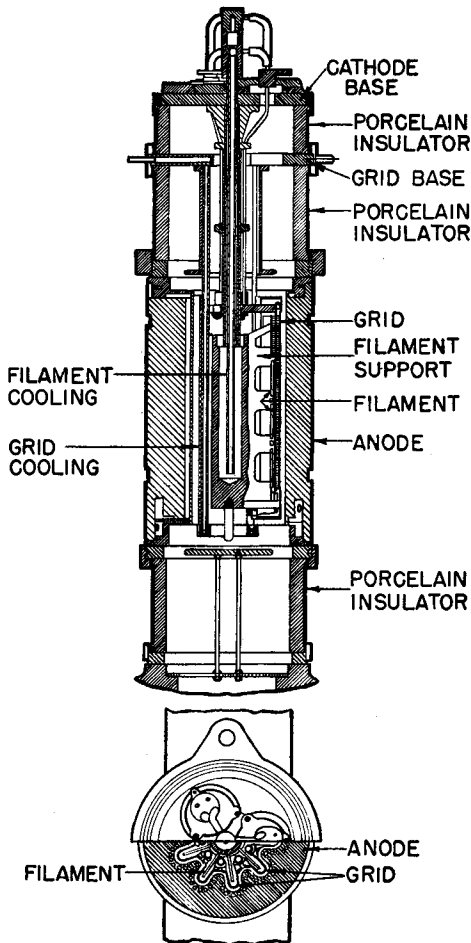

Fig. 13—Inner structure of the 500-kilowatt Metropolitan-Vickers tube.

Yet, there is a field where some of the British and American specialists believe that, even with much lower outputs such as 100 or even 50 kilowatts per tube, one will have to resort to the demountable tubes.

¹⁵ Information received from D. Sloan.

This is the ultra-high-frequency field which utilizes tubes in television and frequency modulation at about or above 60 megacycles. Here, for the suppression of

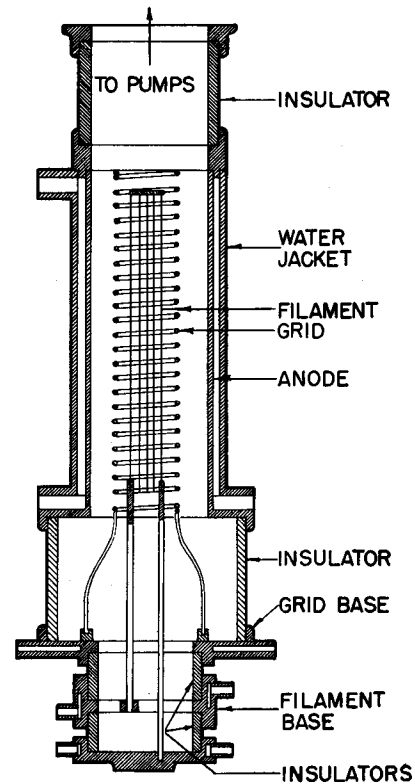

Fig. 14—300-kilowatt Brown Boveri demountable tube with pumping unit.

parasitics, the screen-grid tubes should behave better as power amplifiers than the triodes, and it may seem the demountable type is better adapted to a multielectrode design than the sealed-off type. In fact, demountable screen-grid tubes with 60-kilowatt input ratings have been designed and built by Burch and Sykes in England¹³ for operation at frequencies up to 30 megacycles.

It is interesting to note that quite recently the Brown Boveri Company in Switzerland, obviously under the pressure of the war, entered the field of vacuum-tube production, and they started at once with the demountable design of water-cooled tubes.¹⁶ They have developed a line of demountable type from 10 to 300 kilowatts output for frequencies between 50 and 4 megacycles, respectively. Two 150-kilowatt demountable tubes, DT 20/150 (Fig. 14), are said to have been successfully operated for several months in a broadcast station with 20 kilovolts on the plate. Another type DT 15/25 with 40 kilowatts output for two tubes in push-pull were used in a cyclotron installation in Switzerland.

One may also mention radio station, Allouys, in Southern France, which, according to information obtained from Chevigny, was, in 1939, equipped with two demountable tubes of the French Thomson-Houston

¹⁶ A. Gaudenzi, "High-power demountable transmitting tubes," *Brown Boveri Rev.*, pp. 389-393; December, 1941.

TABLE II
DEMOUNTABLE TUBES

Tube Type	Date of Design	Output Power	Operating Voltage	Filament Data						Anode Diameter	Operating Frequency	Remarks	Reference
				Emission Current	Voltage	Heating Current	Heating Power	Number of Strands	Approximate Length				
		KW	Volts	Amps	Volts	Amps	Watts	§	Inches	Inches	MCS		
<i>France</i>													
Holweck, 2LD-10A	1923	10	7,500	6	(17)	38	(640)	2	4	1.75	Low	5	
Holweck	1927	30	7,500	16	(17)	100	(1,700)	4	6	1.75	Low	1	
Holweck, LD65-10A	1931	150	7,500	(120)	40	400	16,000	8	16	(3)	Low	7	
Chevigny	1938	400	17,500	100	30	635	19,050	18	(14)	(15)	20 max	21	
French Houston-Thomson Co.	1939	200									15		
<i>England</i>													
Metropolitan-Vickers	1930	350	10,000	(90)	19	160 per phase	9,000	9	(20)	24	Low	Water-cooled molybdenum grid	12
Metropolitan-Vickers, 330A	1934	20	10,000	(21)			1,500				7-20		13
Metropolitan-Vickers	1934	40									30	Screen-grid tube	13
<i>Switzerland</i>													
Brown-Boveri, DT 20/150	1939	300	20,000	(100)	32	430	13,560				43		16
	1939	10	8,000	4	7	75	525				60		16
<i>U. S. A.</i>													
University of California	1935	100	20,000	(50)	12	450	5,400	6	12	4	70	Water-cooled copper-grid tube is used in several research projects	15
GE	1940	150	8,500	(50)	18	100 per phase	5,600	12	—	—	95	Thoria-sprayed filaments	17

Numbers in parenthesis are those indirectly estimated.

Missing figures indicate that no information was available at the time of making this Table.

Between the largest and the smallest tube of Brown Boveri shown in the table there are three tubes with intermediate ratings.

The demountable 350- to 400-kilowatt tube designed by Chevigny in France was built only for design tests of the final sealed-off structure of the 3067 tube shown in Table I.

make; its transmitter was operated at 15 megacycles with 100 kilowatts carrier output.

Some data for the known demountable tubes are collected in Table II. It is necessary to state that in this country some experimental work with demountable tubes for radio application has recently been conducted by several large tube manufacturing companies;¹⁷ however, with the existing limitations in power output of broadcast transmitters there was no particular need for the demountable tubes.

Undoubtedly, the most favorable, though still debatable, field for demountable tubes is for industrial applications other than radio, mostly for the purpose of rapid and easily controllable heating of various materials.

Historically, the first industrial application of high-frequency power was the very field of vacuum-tube manufacturing, where high-frequency heating was used for outgassing tube parts either in the preassembly stage or during the final exhaust. This problem originally required relatively low power. Between 1917 and 1922, pioneered by Northrup, alternating-current induction melting of metals in lots of about 20 pounds,¹⁸ was tried out by many laboratory workers; then, during the 1920's induction furnaces, from 20 to 16,000 pounds capacity, were built in this country and abroad. Power of low frequencies, from 60 to 10,000 cycles per second, seemed to be satisfactory, so that in this application electronic tubes could not compete too successfully with motor generators or spark-gap oscillators.¹⁹ About 10 years ago, with the advent of ultra-high-frequency tubes

capable of generating power of several tens of kilowatts at frequencies²⁰ up to 60 megacycles, many interesting experiments were started in this country. Thus, the Westinghouse Company in co-operation with the prospective users of high-frequency apparatus carried out a series of experiments, such as grain disinfestation in grain elevators; killing moths in chocolate and other food factories, sterilization of expensive breakfast foods in packages; application in industries where glass or other dielectrics had to be heated; drying of tobacco leaves; and other experiments. To this list one also must add the modern therapeutic applications of ultra-high-frequency power. Many of these projects were successful from the research viewpoint. However, commercially the high-frequency methods mostly could not compete at that time with the old methods, such as food desinfestation by simple, or "vacuum" fumigation, or with ordinary furnace heating, because of the high cost of vacuum tubes and associated equipment. With the beginning of the war, many old projects have been revived and a number of new ones started. The question of expense no longer played the first role as soon as there was a physical possibility of doing certain required work. Therefore, the industrial application of high-frequency oscillators progressed rapidly, and in many cases their decided advantages over the old methods could no longer be doubted. An example of the outstanding industrial application of high-frequency power is the tin reflowing project; it not only accelerated the rate of production of tinned iron sheet, but permitted saving up to 66 per cent of tin and simultaneously considerably improved the quality of tinning. Twelve tubes of WL-895 type (Fig. 15) are used in each tin-reflowing installation with the total output of 1200

¹⁷ Commercial Engineering Developments, "Demountable vacuum tubes," *Proc. I.R.E.*, vol. 28, p. ii, April, 1940.

¹⁸ G. H. Clamer, "The development of the coreless induction furnace," number 10 in a series of case histories in metallurgical research, *Metals and Alloys*, vol. 6, pp. 119-124; May, 1935.

¹⁹ C. C. Levy, "Electrical equipment for induction furnaces," *Elec. Eng.*, pp. 43-47; January, 1934.

²⁰ I. E. Mouromtseff and H. V. Noble, "A new type of ultra-short-wave oscillator," *Proc. I.R.E.*, pp. 1328-1345; August, 1932.

kilowatts at 200 kilocycles per second. Another important project, annealing of aluminum sheets, demands almost twice this power. No wonder that the question of the demountable versus sealed-off tubes emerged again as an important problem.



Fig. 15—100-kilowatt Westinghouse 895 tube.

The opinion of the specialists is at great variance on this subject. The designers of the demountable tubes, naturally, are very enthusiastic about them. The Brown Boveri engineers go in this direction so far that they consider the sealed-off tubes almost unnecessary even for low outputs.¹⁶ This however, may be explained by some specific manufacturing conditions. Many other radio specialists are decidedly against the demountable tubes and prefer to have sealed-off tubes of any size, even if they are expensive.²¹

There is no experience available in this country with commercial installations employing demountable tubes. As stated before a few research installations cannot be taken as a basis for sponsoring commercial projects, even if the tubes are favorably commented upon. Indeed, in an industrial project neither scientific nor highly trained personnel will be permanently available for servicing the equipment, nor will casual interruptions

²¹ G. Chevigny, "Tubes for high-power short-wave broadcast stations—Their characteristics and use," *Proc. I.R.E.*, vol. 31, pp. 331-340; July, 1943.

in operation be tolerated; ordinarily, interruptions are not fatal to research projects. On the other hand, as has been frequently and logically suggested, the demountable tubes may be expedient in case a much higher power is required than feasible with the available sealed-off tubes. This opinion has been repeatedly endorsed even by many radio and tube engineers, but as a rule, in a noncommittal way; indeed, thus far in all practical cases the new problems have been solved without resorting to the demountable-tube structure.

The main advantage claimed by the designers and proponents of demountable tubes is the "unlimited" life of the tube in service. In the sealed-off type life of a tube ends with the first burnout of the filament. After this, the tube is to be practically scrapped, as very little of it can be salvaged economically. The life of modern high-power tubes is designed to be approximately 10,000 hours. Thus, with the sealed-off tubes in continuous operation all year around (8800 hours), the customer has to buy an entire tube complement every 14 months. In a demountable tube, a burned-out strand can be replaced on the spot, as has frequently been claimed, in a few seconds⁵ or at least minutes,¹³ and the same tube can be used over again almost indefinitely. So it seems that the cost of renewal tubes in the first case must be compared to the corresponding cost of filament renewals in the demountable tubes plus, of course, the cost of acquisition and servicing of the pumps. Considering, in addition, that the demountable tube can be designed in any large size so that it may replace two or more sealed-off tubes, the maintenance expense may shift the economic balance still further in favor of the demountable tube.

A remark must be made here that many designers of the demountable tubes recommend operation of their cathodes at higher temperature than is common with the sealed-off type, in order to take full advantage of the demountable structure and to increase power from a single tube. Then, of course, the filament replacement occurs more frequently than normal. Thus, Holweck operates his filaments at 2700 degrees centigrade; this requires their renewal every 200 or 300 hours.¹ The Metropolitan-Vickers designers¹³ indicate that 1500 hours is the normal life of their filaments, but they advise making filament inspection every 500 hours. It may be remarked further that one can hardly recommend the replacement of a single filament strand at a time, for this simple reason: when one strand ends its life by burning out, all other strands are also near the end of their life. Hence, it is expedient to replace all strands each time a burnout occurs in order always to have them of the same age; this will prevent more frequent stoppage in tube operation. The accelerated filament renewal should obviously result in more frequent interruption of tube operation.

Other advantages claimed for the demountable tubes are: the capability of being overloaded almost 50 per cent over a short period without fatally damaging the

tube; the possibility of matching tube characteristics at the place of their use; elimination of glass-blowing work leaving purely mechanical engineering methods for their manufacture, and, therefore, as was implied before, no limit to the size of the demountable tubes. Finally, one can reiterate the contention that demountable structures are better adaptable to multi-electrode designs of large tube than the sealed-off types.

Side by side with the claimed advantages of the demountable type one must list the objections which can be made to it. First, although the act of replacing a filament strand in a demountable tube may be as short as a few minutes or even seconds, in reality by a single burnout the tube is put out of working condition probably for several hours. Indeed, after a burnout occurs and the power is shut off, one must allow a certain time for sufficient cooling of the inner structure before the tube can be opened, to prevent oxidation of the parts. Then, the process of opening the tube also takes a certain time, depending on its structure and the design of vacuum-tight joints, the tube size, etc.; this time may be not inconsiderable, as the use of auxiliary mechanisms may be required; hydraulic jacks are used in the large Metropolitan-Vickers tube. Finally, the tube after it has been open in the atmosphere cannot be put immediately into high-voltage service; it must be seasoned, and seasoning may take many minutes and even several hours. Hence, a definite demand: if uninterrupted service of the installation is of paramount importance, a spare tube and complete equipment for seasoning the tubes are necessary in the case of demountable tubes.

One of the important problems in construction of demountable tubes is the vacuum-tight joints between tube parts. The original rubber gaskets were abandoned both by Holweck, and by the Metropolitan-Vickers designers, in favor of stopcock grease, wax, or some bituminous compounds. The joints need maintenance work and occasional replenishment of the sealing compound. There are, also, suggestions of using tin-soldered joints, the opening and closing of which would, of course, take considerable time.

Another major objection to demountable tubes is the necessity of the inclusion in an industrial installation of a delicate vacuum system with several pumps which have to be continuously operated.

In this respect the description of the original 4-stage exhaust equipment attached to the 500-kilowatt Metropolitan Vickers tube is interesting.²² It consisted of (1) A mechanical backing oil pump, (2) A high-capacity low-speed oil-vapor pump, (3) two high-speed oil-vapor pumps in parallel, and (4) ten high-speed oil-vapor pumps in two groups of five. Undoubtedly, a much simpler exhaust equipment can be and has been

designed, but the pumps are still objectionable for two reasons. They must be attended by specially trained personnel. Then, they must be periodically cleaned and oil replaced; under conditions of industrial operation, this must be done probably more frequently than once a year as is claimed by certain designers; naturally, during cleaning the pumps are always subject to all kinds of hazards. Again, after the vacuum system and oil pumps have been cleaned and reassembled they must be run for many hours or even for a couple of days before the system again can be put in service. Hence, spare vacuum system and pumps must be available.

Even after the tube has been simply idle for some time, without having been opened to the air, the pumps must be started ahead of the time scheduled for tube work. This preparatory period may change, depending on tube design, from 20 minutes to more than an hour.

Finally, it has been indicated by Burch and Sykes¹³ that there are greater difficulties in the elimination of flashovers in the 500-kilowatt tubes than in the smaller one;²³ also, that stability of operation and filament life can be different from those of the sealed-off tubes. This is reflected in the relatively low operating voltages prescribed for their demountable tubes.

Undoubtedly, in the absence of positive experience, a psychological element will play an important role in making the choice between the demountable and sealed-off tubes in each particular case. If all the facts are presented to the customer, it remains for him to decide whether he wants to endure certain inconveniences connected with operating demountable tubes in exchange for economic advantages. In each individual case, economic loss through probable interruptions in tube operation must be taken in consideration; also the possibility of elimination of interruptions through preventive replacement of filaments before their life is fully utilized. In this respect, intermittent operation may be relatively favorable to the demountable tubes as it allows time for necessary repair and inspection.

There is another aspect to the problem of whether demountable or sealed-off tubes are to be used in an industrial project. This is, whether the high-frequency power must or can be used concentrated, at a single heating circuit; or if the industrial process will be better performed in a sequence of less powerful high-frequency circuits. In the latter case a single huge tube will be of less advantage than several smaller ones; hence, the demountable structure loses this point in its expediency.

Thus, it seems that the problem of the demountable versus sealed-off tube must be considerably clarified in the future if a customer in co-operation with the tube and equipment manufacturer would decide to pioneer in this field, that is, to go "all out" for the demountable tubes, even without the assurance that this will be the best solution. For encouragement, one may point out that with improved technics, better demountable tubes

²² A. S. Angwin, Wireless Section, Chairman's Address delivered before the Institution, October 22, 1931, *Jour. I.E.E.* (London), vol. 70, pp. 33-34; December, 1931, to May, 1932.

²³ This may perhaps be ascribed to the fact that the anode of this tube is made of iron, not copper.

and better vacuum pumps can be designed now than those described in the literature of several years ago. In addition, one must admit that individual sealed-off tubes can be designed for outputs not above 300 or 600 kilowatts; beyond this rating the sealed-off tubes will, in all probability, become too bulky and too heavy to be conveniently manufactured, handled, and transported. A simple problem of heat dissipation can corroborate this. The practical dissipation limit for a large water-cooled tube is approximately 500 to 600 watts per square inch. Hence, a tube having a filament length of 20 inches and the anode 5 inches in diameter will be capable of dissipating $20 \times \pi \times 5 \times 0.6 = 180$ kilowatts. At 75 per cent efficiency this corresponds to an output of 540 kilowatts. The net weight of such a tube will be over 100 pounds and its length about 7 feet; this is almost the limit of convenient handling of the tube in the factory and in commercial installations.

Looking into the future of high-power industrial and radio tubes, one may anticipate that attempts will be made to design cathodes for longer life, for example, by replacing the present filamentary cathodes by the indirectly heated cathodes in the form of cylinders brought to the proper temperature either by heaters located inside a cathode as has been done in the 300-kilowatt Telefunken tube, or by making the cylinder the anode with respect to the internal auxiliary cathode.

Columbium used in the German tube has an advantage over tungsten as the desired emission current can be obtained with only 60 per cent heating power. Tantalum may be another suitable material, although it requires about 30 per cent more power than Columbium. An indirectly heated cathode even with a hole burned through does not end its life abruptly but gives a timely warning when it should be replaced.

Another avenue of promising development of high- and even medium-power industrial tubes is connected with the ever increasing use of Kovar in high-vacuum-tube structures. Although this metal was invented about 15 years ago, its application in high-frequency tubes was extremely limited for a long time. During the last few years, partly because of considerable progress in the art of welding and brazing tube parts made of different metals, the good points of Kovar were clearly demonstrated: the sturdy Kovar seals have been successfully used in combination with copper anodes even in ultra-high-frequency tubes. On the other hand, through welding Kovar to other metals, the use of steel for tube structural parts is permitted. This leads to designs similar to the sealed-off ignitron in which seam-welding is used as the last operation in assembling a large tube, instead of making a huge conventional glass-to-glass seal between the bulb and a heavy glass dish 5 or 6 inches in diameter. Such procedure permits the design of *semidismountable* tubes (Fig. 16). If properly designed along these lines, a customer's tube with a burned-out filament can be opened *at the factory* mechanically by accurately cutting away of the welded

joints, the defect repaired, and the tube closed again without subjecting it to the high heat and hazards of glass-blowing fires. Reassembling and re-exhausting of such tubes will be easier and cheaper than making a new tube, and all parts, except for the damaged one, will be used over again. The same individual tube can

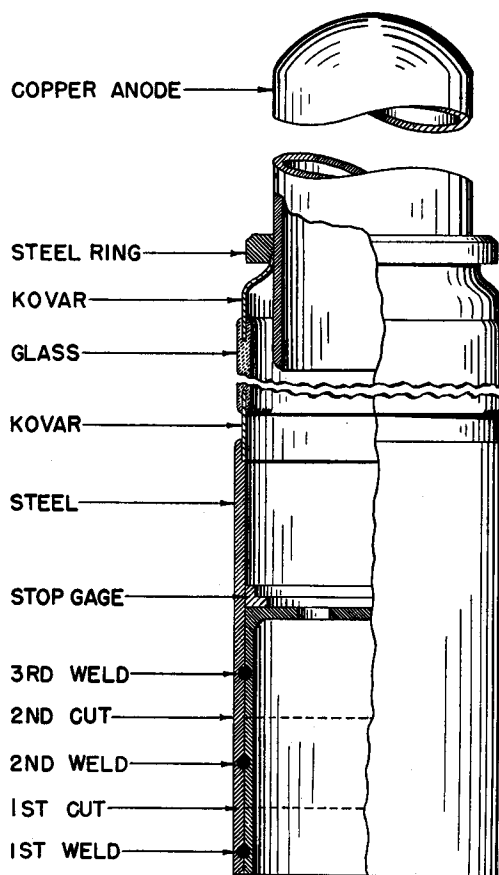

Fig. 16—A feasible semidismountable design with Kovar seals.

be repaired two or three times which will considerably reduce the cost of a unit tube in long-time operation. The semidismountable tubes may possess the good point claimed for the demountable tube, long life; at the same time they do not have the bad points of the demountable tubes, complicated auxiliary equipment and the necessity of skilled personnel to attend it.

CONCLUSIONS

It seems that a careful comparison of the virtues and drawbacks of demountable and sealed-off tubes with equal power per tube would surely lead to a verdict in favor of the sealed-off type. Chevigny, in his study²¹ of the 350- to 400-kilowatt tube arrived at the conclusion that with tube life of 10,000 hours the cost per hour of the sealed-off tube is lower. However, if one demountable tube can replace several sealed-off tubes, the situation may be quite different, as not only the number of tubes in operation will be reduced but the entire equipment may be simplified. In each industrial project the solution may vary. As to the necessity of

having vacuum pumps in operation and the attending personnel, one may be reminded that recent years of defense work showed that even unskilled personnel may be trained sometimes to perform complicated operations. It seems that demountable tubes have much less chance in radio transmitters when even short interruptions are intolerable. This can be illustrated by

the suggestion of Metropolitan-Vickers designers of the demountable tubes to have sealed-off tubes as spares in radio transmitters. Yet, even in radio, demountable tubes can find application in special cases when tubes of a new design are required in numbers not large enough to justify the development and manufacturing expense of the sealed-off type.

The Mechanism of Supersonic Frequencies as Applied to Magnetic Recording*

HERSHEL TOOMIM†, NONMEMBER, I.R.E., AND DAVID WILDFEUER‡, NONMEMBER, I.R.E.

Summary—The addition of a supersonic current to the signal current in recording on a magnetic medium results in recordings of low-harmonic distortion. Recording in this fashion is an accepted part of the art, although it is not well understood. The mechanism whereby this type of recording operates is presented in Part I.

An extension in the oscillographic technique of obtaining *B-H* curves of magnetic specimens is presented in Part II. A circuit is presented which makes possible simultaneous viewing of major and minor hysteresis loops.

PART I

IT IS the objective of this discussion of magnetic recording methods to indicate the mechanism whereby the newly introduced "high-frequency-bias system"¹ operates.

The process of magnetic recording, previous to the introduction of "high-frequency bias," utilized a magnetically saturated medium which was demagnetized by an amount proportional to the amplitude of the recording signal. This system was first developed by a German engineer, Stille, who made a careful study of the problems associated with the recording of sound on a magnetic medium. Magnetic recordings of high quality utilizing this system were made in Great Britain.² Other successful machines have been built all utilizing the same magnetic principle. Those using magnetic tape have used either longitudinal or transverse magnetization, while those using wire have all depended on longitudinal or axial magnetization.

The magnetic recording, as developed by Stille, utilized a magnetic medium, such as steel tape which was drawn consecutively through a magnetizing head and a recording head and subsequently, for the purpose of reproduction, through a reproducing or pickup head. The magnetizing head was utilized to saturate

the medium magnetically and remove simultaneously any previous recording. An alternating or signal magnetomotive force was applied to the recording head in addition to a magnetomotive force of constant amplitude which, in the absence of a signal, was just sufficient to reduce the remanent flux in the medium to zero. The signal either increased or decreased this constant magnetomotive force and therefore the remanent flux in the medium was either positive or negative depending upon the sign of the recording signal. The magnetomotive force of constant amplitude was of opposite polarity to that of the magnetizing head.

In contrast to the above system, the "high-frequency-bias system" of recording takes place on a magnetically neutral medium. This neutral medium is passed continuously through a recording head to which a signal consisting of audio and supersonic components is applied. This current is used to subject the magnetic medium to a concentrated magnetic field. Each elementary length is subjected to a magnetomotive force with a slowly varying component and a high-frequency component which traverses several cycles during the time the element is in the magnetic field. It is important to realize for the understanding of the subsequent discussion that hysteresis loops, as shown in the various figures, refer only to an elementary volume of magnetic material and each new element of material entering the recording head embarks on its magnetic journey on the hysteresis loop from a completely neutral condition. A recording made on a magnetically neutral medium in the absence of "high-frequency bias" contains large amounts of odd-harmonic distortion and has an input-output characteristic of the type of Fig. 1. This shape of transfer characteristic is highly irritating to the ear and results in almost unintelligible speech reproduction. The addition of "high-frequency bias" in the proper amount causes the recording characteristic to be linear to the origin and symmetrical in the first and third quadrants about the origin, as in Fig. 2. It will be noticed from Fig. 2 that the overload characteristic is of a type to which the ear is least

* Decimal classification: 621.385.97×538. Original manuscript received by the Institute, May 2, 1944.

† Research Engineering Division, Lewyt Corporation, New York 7, N. Y.

‡ Eisemann Corporation, Brooklyn, N. Y.

¹ D. W. Pugsley, "Engineering details of magnetic wire recorder," *Electronic Indus.*, vol. 3, pp. 116-118; January, 1944.

² A. E. Barrett and C. J. F. Tweed, "Some aspects of magnetic recording and its application to broadcasting," *Jour. I.R.E.* (London), vol. 82, pp. 265-288; March, 1938.